



# Amp5

Charging system with ChargePod and ConnectBar



## Installation manual



Scan the code to watch the installation video

# AmpSociety

Charging without compromise

© AmpSociety International AB 2026

The contents of this document are subject to revision without notice due to developments in methodology, design and manufacturing. AmpSociety International AB assumes no legal responsibility for any errors or damages resulting from the use of this document.

# Table of contents

<b>01 Introduction</b>	<b>6</b>
1.1 About the manual	6
1.2 Symbols in the manual	6
1.3 Warranty	6
1.4 Installation support	6
<b>02 Safety</b>	<b>7</b>
<b>03 Product overview</b>	<b>8</b>
<b>04 Before installation</b>	<b>9</b>
<b>05 Installation</b>	<b>11</b>
5.1 SmartHub location	11
5.2 Wall mounting of SmartHub	12
5.3 Ground mounting of SmartHub	13
5.4 Ranges of ConnectBar lengths available	17
5.5 Mounting ChargePod and ConnectBar on poles	18
5.6 Install ConnectCover for single-sided power bar	31
5.7 Mounting ChargePod and ConnectBar on wall	31
5.8 Install ConnectCover for single-sided power bar	31
5.9 Install WallConnection	40
5.10 Install GroundConnection	46
5.11 Install ChargeHook	53
<b>06 Electrical installation</b>	<b>55</b>
6.1 SmartHub components	55
6.2 Connect SmartHub	56
6.3 Connect the network from ChargePod to SmartHub	57
6.4 Connect Router AmpSociety (part no. 5000207, option for Amp5)	58
6.5 Connect external stop	59

6.6	Lighting connection (optional)	59
<b>07 Commissioning</b>		<b>60</b>
7.1	Start-up	60
7.2	Electrical testing	64
7.2.1	Insulation testing	64
7.2.2	Z-line test	65
7.2.3	RCD test	65
<b>08 Care</b>		<b>67</b>
8.1	Cleaning the charging system	67
8.2	Visual inspection	67
8.3	Check the residual current circuit breaker	67
<b>09 End use</b>		<b>69</b>
9.1	LED indicators	69
9.2	Thermal limitation	69
9.3	RFID reader	69
9.4	Display components	70
<b>10 Troubleshooting</b>		<b>72</b>
10.1	Error codes	72
<b>11 Load balancing</b>		<b>74</b>
11.1	Carlo Gavazzi EM530	74
11.1.1	Connect the EM530 energy meter	75
11.1.2	Configure EM530	76
11.1.3	Menu selection EM530	77
11.2	Carlo Gavassi EM210	78
11.2.1	Connect the EM210 energy meter	79
11.2.2	Configure EM210	80
11.2.3	Menu selection EM210	81
11.3	Schneider iEM3555	82
11.3.1	Connect the iEM3555 energy meter	83

---

11.3.2	Configure iEM3555 for load balancing	84
11.3.3	Menu options iEM3555	86
11.4	Load balancing over the internet	86

---

## **12 Technical data** **87**

---

12.1	Amp5 product specification	87
12.2	Ground anchorage	90

# Introduction

---

## About the manual



### Warning!

**Always read and understand all safety instructions and procedures described in this manual before attempting to install, use or perform maintenance on the Amp5.**

This manual aims to guide the installer through the mounting and electrical installation of the Amp5 charging system (SmartHub, ChargePod and ConnectBar).

## Symbols in the manual



### Warning!

**Indicates a hazardous situation which, if not avoided, could result in serious injury or death.**



### Caution!

Indicates a situation which, if not avoided, could lead to property damage or minor to moderate injury.



### Keep in mind!

Additional information to take into account.

## Warranty

The following requirements must be met for AmpSociety International AB's warranty to apply:

- The installation must be carried out by qualified personnel.
- The installation must be carried out as described in the instructions in this manual.
- Repairs and maintenance of the ChargePod must be carried out by AmpSociety International AB.
- Repairs and maintenance of SmartHub must be carried out by AmpSociety International AB or an authorised workshop.
- The seal of the ChargePod must not be broken.
- The Amp5 Self-Inspection/Warranty Certificate form and accompanying checklist have been completed.

To make a warranty claim, please contact AmpSociety and request a form.

## Installation support

For installation and commissioning support, please contact AmpSociety.

- Telephone: +46 101 499 500, open weekdays 8:00–17:00 (CET) (except for public holidays)

# Safety

---



**Warning!**

Electrical installation may only be carried out by a qualified electrician.



**Warning!**

Ensure that all personnel have read and understood all essential information and have the necessary training to carry out the work.



**Warning!**

Follow all relevant local, regional and national requirements for installation, repair and maintenance.



**Warning!**

Stop using the product immediately if it is damaged in any way.

# Product overview



**Keep in mind!**

Charging systems can take different forms. The illustration shows an example.

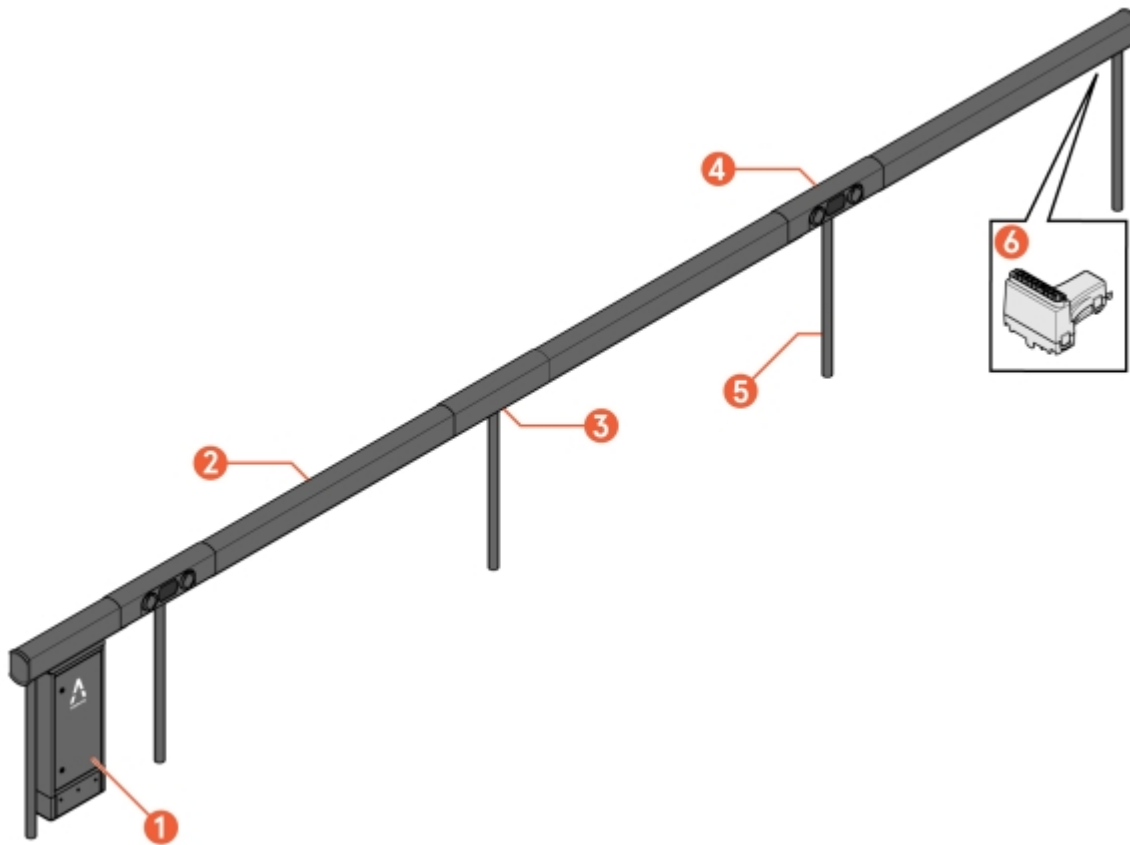

Image 1: Amp5 – overview

- 1 SmartHub
- 2 ConnectBar (cable included)
- 3 Bracket (pre-mounted pole bracket)
- 4 ChargePod
- 5 Pole
- 6 ConnectBar EndModule

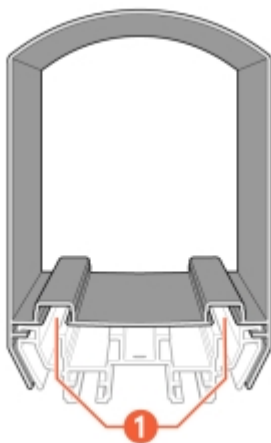

Image 2: ConnectBar – side view

- 1 LED strip slot

## Before installation

---

- 1 Ensure that all personnel have read and understood all essential information and have the necessary training to carry out the work.



### Caution!

Care must be taken during installation of the Amp5 system to avoid scratching materials and damaging cables on sharp edges.

- 2 Check against the delivery note that all components have been provided, and that nothing is damaged or incorrect.

- 3 Make sure that the planning documents are available, such as the construction drawing.



### Keep in mind!

Amp5 requires no cutting or drilling during installation. The right quantity and size of system components are provided right from the start. Planning documents should have been created using the configuration tool in AmpPortal.

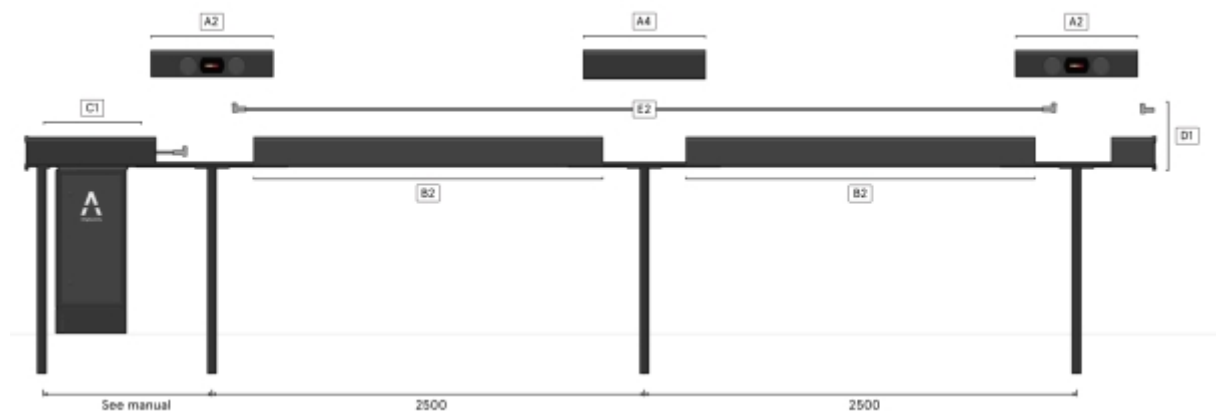

Image 3: Example of a construction drawing

- 4 Make sure that the necessary tools and materials are available.



**Keep in mind!**

Which tools are needed may vary depending on the conditions on site and in the project. Prepare for the work by reading the entire manual before commencing.

**Examples of tools that may be needed:**

- T20, T25, T30 and T40 bits
- 8 mm socket, length > 40 mm
- 10 mm socket

**Examples of materials that may be required (not included in the delivery from AmpSociety):**

- Ground screw or concrete foundation (Saferoad, 600500 FundSafeR60/500) for pole installation
- Cable protection, cable ladders or other ducting material
- Edge strips for chafe protection
- Cable protection tube

# Installation

---

Amp5 can be wall or ground mounted.

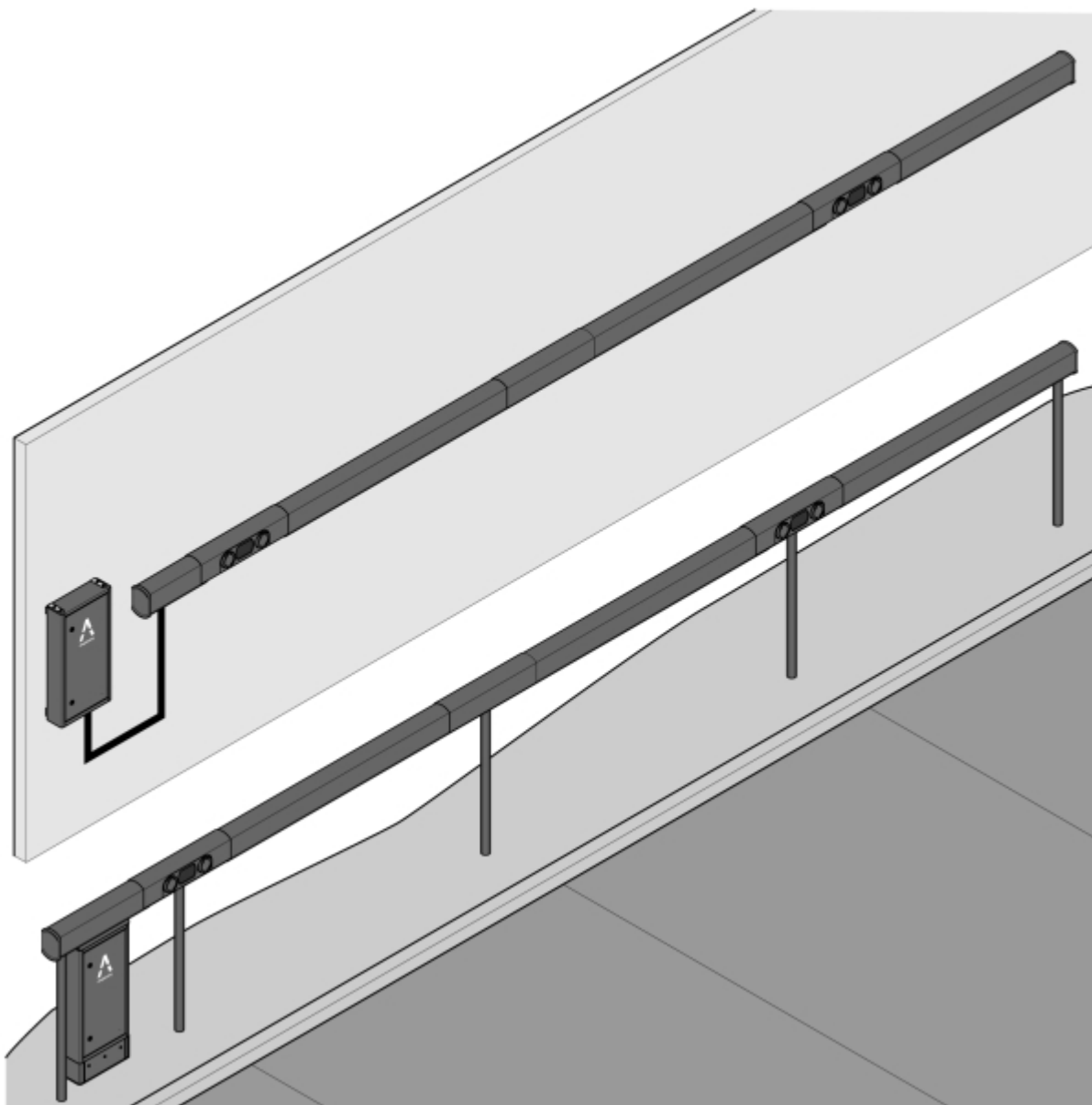

## SmartHub location

Choose a protected location for SmartHub that minimises the risk of collision and provides accessibility for servicing.



### Keep in mind!

There must be free clearance in front of SmartHub so that the door can be opened.

It is also possible to rotate the entire SmartHub if the door can be opened from the back but not from the front.

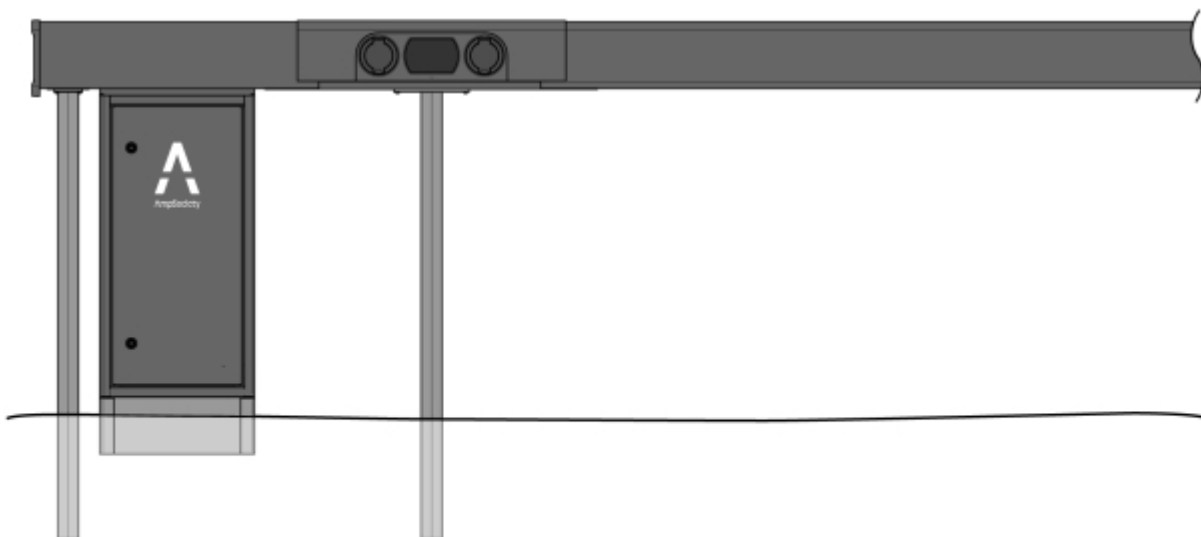

Image 4: Instructions for positioning SmartHub under ConnectBar

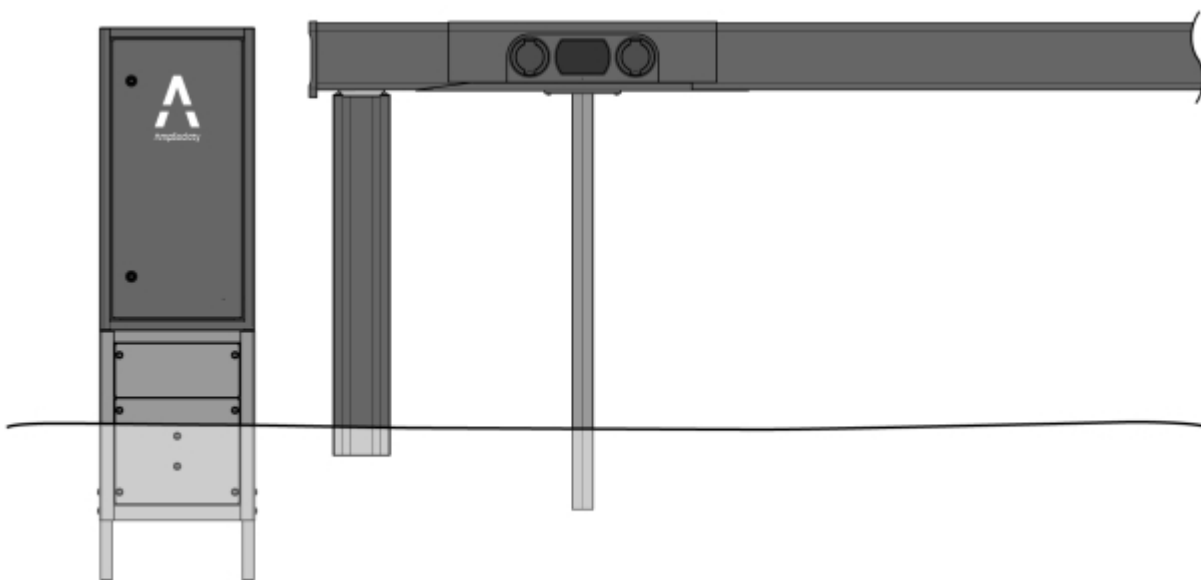

Image 5: Instructions for standalone positioning of SmartHub

## Wall mounting of SmartHub

- 1 Secure the wall brackets to the wall with suitable fasteners (fasteners not included).

## 2 Attach SmartHub to the wall brackets.

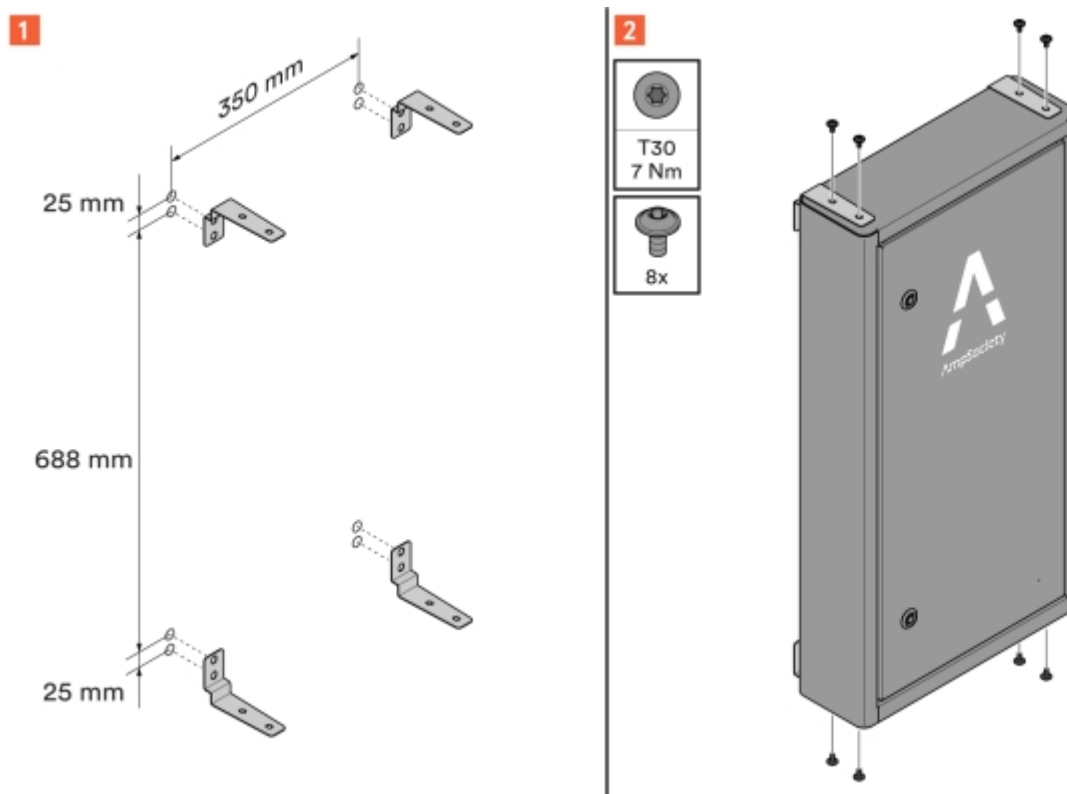

Image 6: Wall brackets on SmartHub

**Keep in mind!**

When using ConnectCable 3/6 m to connect the SmartHub and WallStart, the cable must be protected from UV light.

## Ground mounting of SmartHub

When SmartHub is installed under ConnectBar, a cover skirt is used to cover the incoming cables at the bottom of SmartHub.

**Keep in mind!**

In this case, poles (including attachment) must be installed first. See Section 5.5 "Mounting ChargePod and ConnectBar on poles", **page 18**.

When the standalone SmartHub is mounted on the ground, it must be mounted on a base that has been buried.

## 1 To install SmartHub under ConnectBar:

**1.1** Install the cover skirt on SmartHub.

Image 7: Cover skirt installation

## 1.2 Mount SmartHub at the first pole.

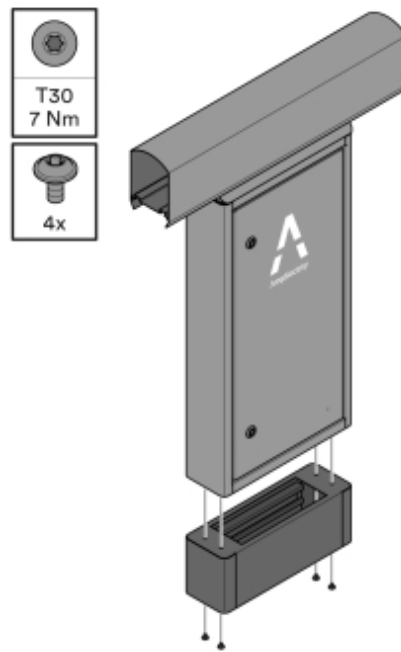

### Keep in mind!

The distance between the poles and the tube outlet from the ground must follow the specification in the instructions.

The poles must be the same height so that SmartHub is horizontal along the top edge and any height differences are not transferred to the rest of the installation.

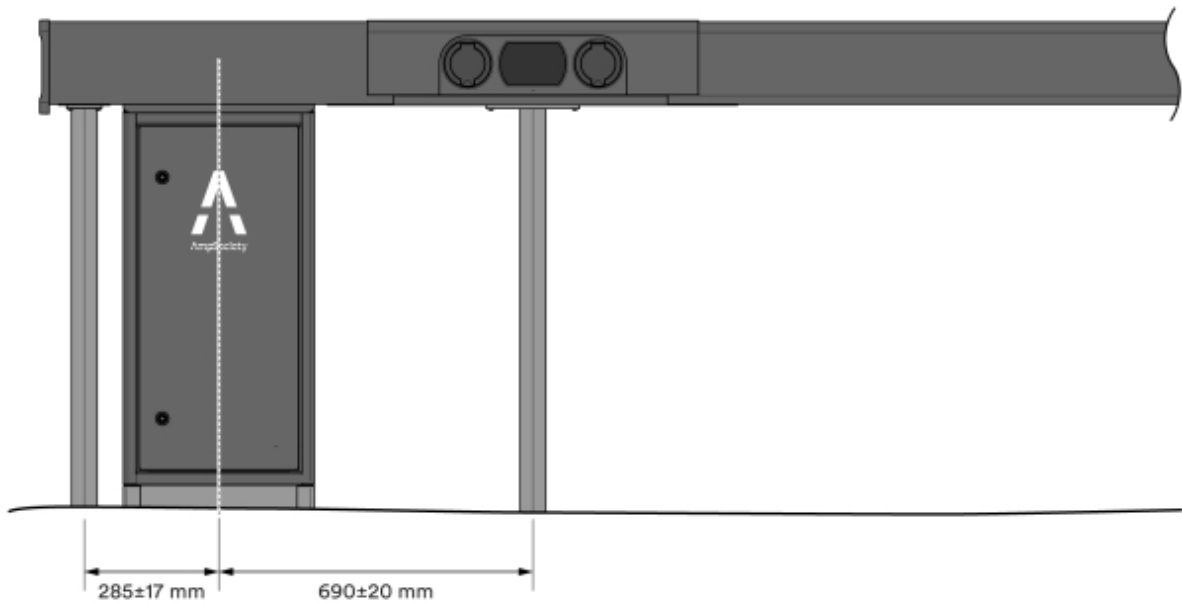

Image 8: Measurement guidelines – one direction

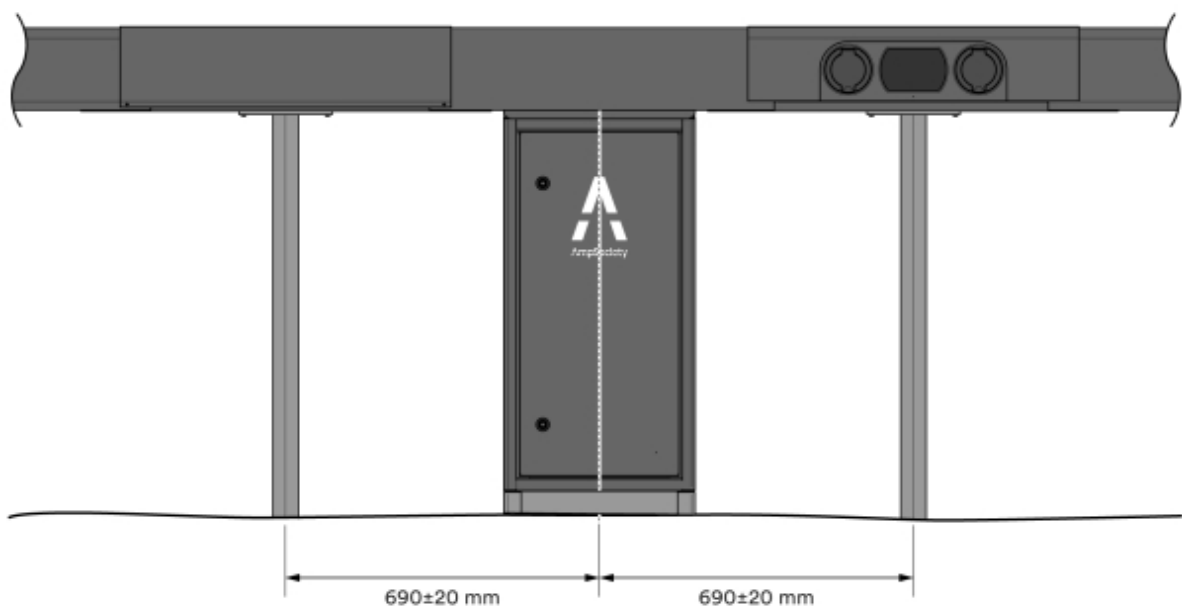
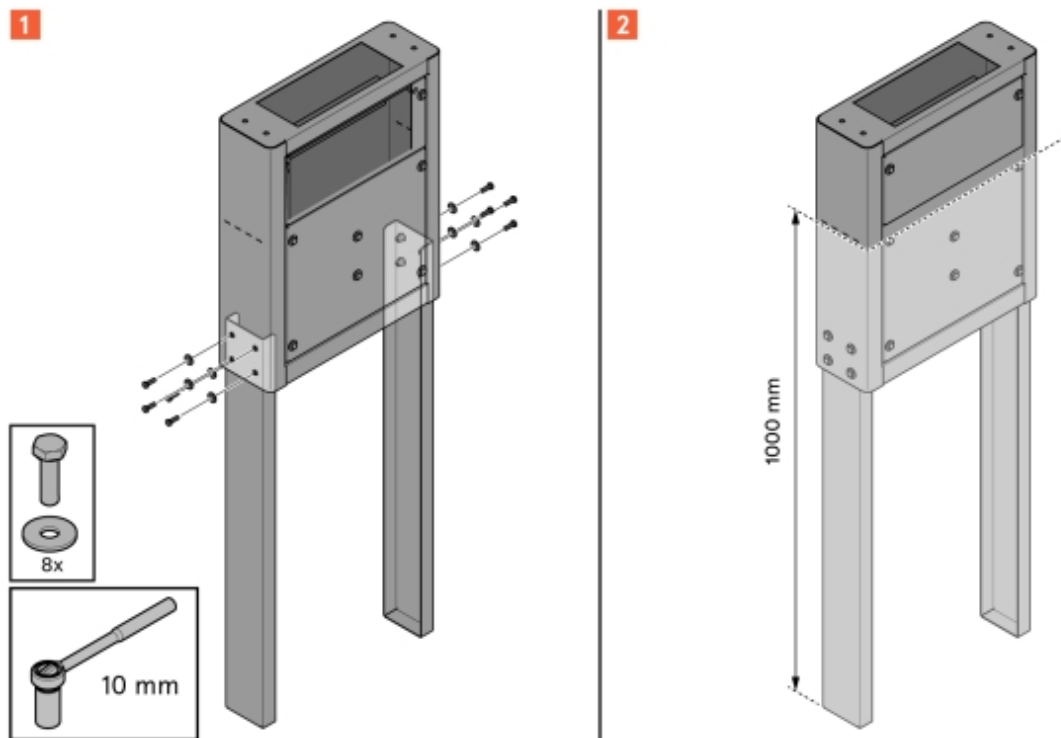

Image 9: Measurement instructions – two directions

2 Ground mounting of standalone SmartHub:

2.1 Fit two foundation legs to the GroundBase.

2.2 Feed the cabling into the base and bury it down to the 1000 mm mark.



2.3 Unscrew the top cover.

2.4 Mounting SmartHub on the GroundBase.

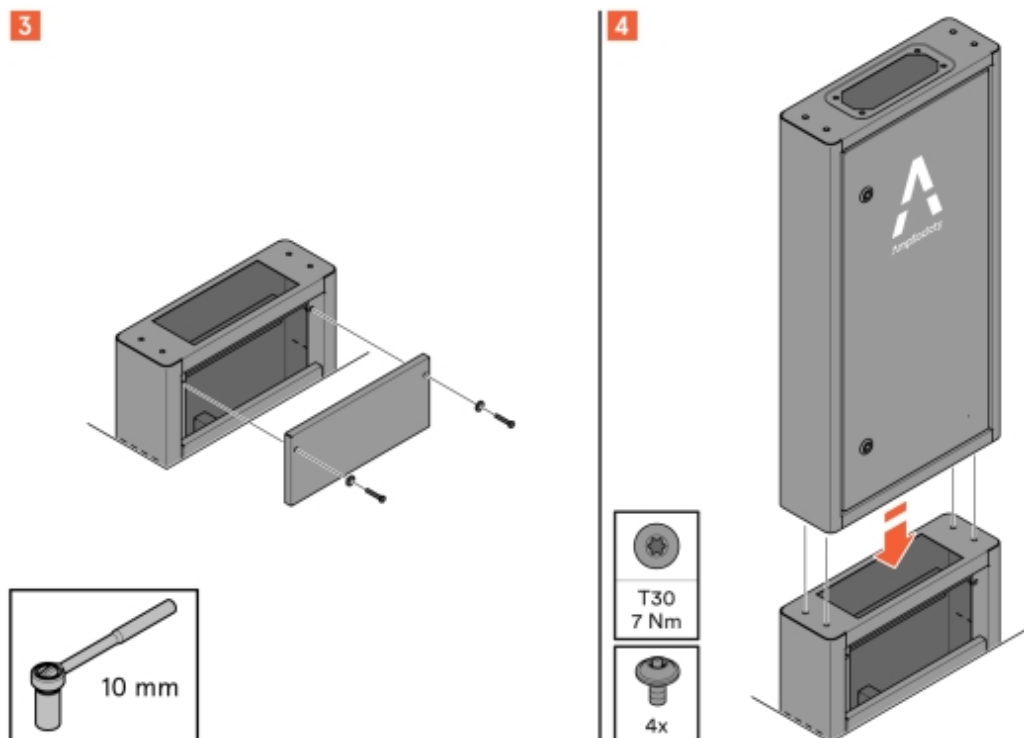

3 Check that SmartHub is straight.

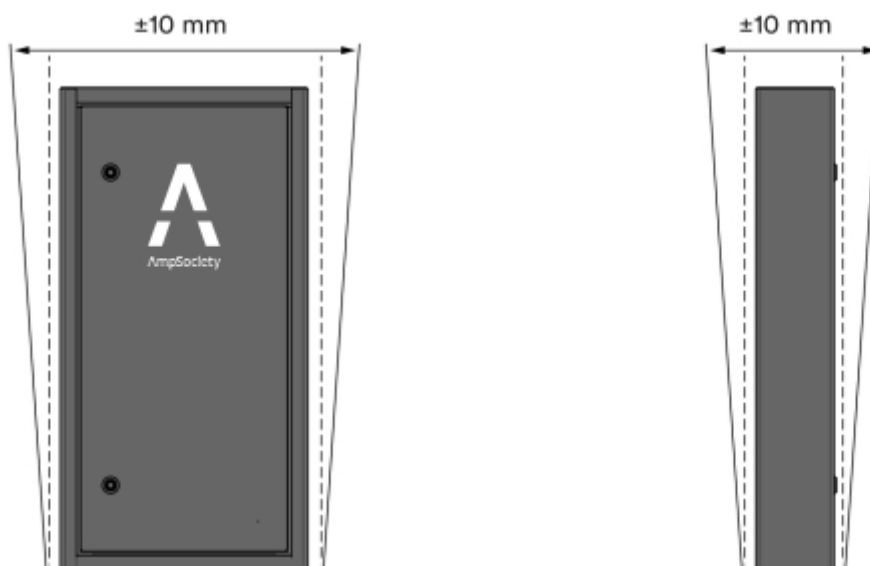

Image 10: Checking straightness

4 Check that SmartHub is stable.

- When SmartHub is mounted on the base, it should not have any movement forward/backward.

## Ranges of ConnectBar lengths available



### Keep in mind!

The ConnectBar can be cut to shorter lengths if required.

Table 1: Double-sided parking (+/- 100 mm)

ConnectBar length <b>A</b>	Min. parking width	Nom. parking width <b>B</b>	Max. parking width
1920 mm	2400 mm	2500 mm	2600 mm
2020 mm	2500 mm	2600 mm	2700 mm
2120 mm	2600 mm	2700 mm	2800 mm
2220 mm	2700 mm	2800 mm	2900 mm
2320 mm	2800 mm	2900 mm	3000 mm
2520 mm	3000 mm	3100 mm	3200 mm
3420 mm	3900 mm	4000 mm	4100 mm

Table 2: Single-sided parking (+100 mm/-300 mm)

ConnectBar length <b>A</b>	Min. parking width	Nom. parking width <b>B</b>	Max. parking width
2020 mm	2300 mm	2600 mm	2700 mm
2320 mm	2600 mm	2900 mm	3000 mm
2520 mm	2800 mm	3100 mm	3200 mm

## Mounting ChargePod and ConnectBar on poles

### 1 Determine the position of the post foundations.

- The recommended position is along the edge of the parking space, if possible. If ground conditions make this unsuitable, they can be positioned up to 500 mm from the parking space.
- If the parking width is as indicated in Section 5.4 "Ranges of ConnectBar lengths available", **page 17**, the poles must be installed in intersection points (+) of the parking spaces.



#### Keep in mind!

Use the longest possible ConnectBar in the range to improve its stability.

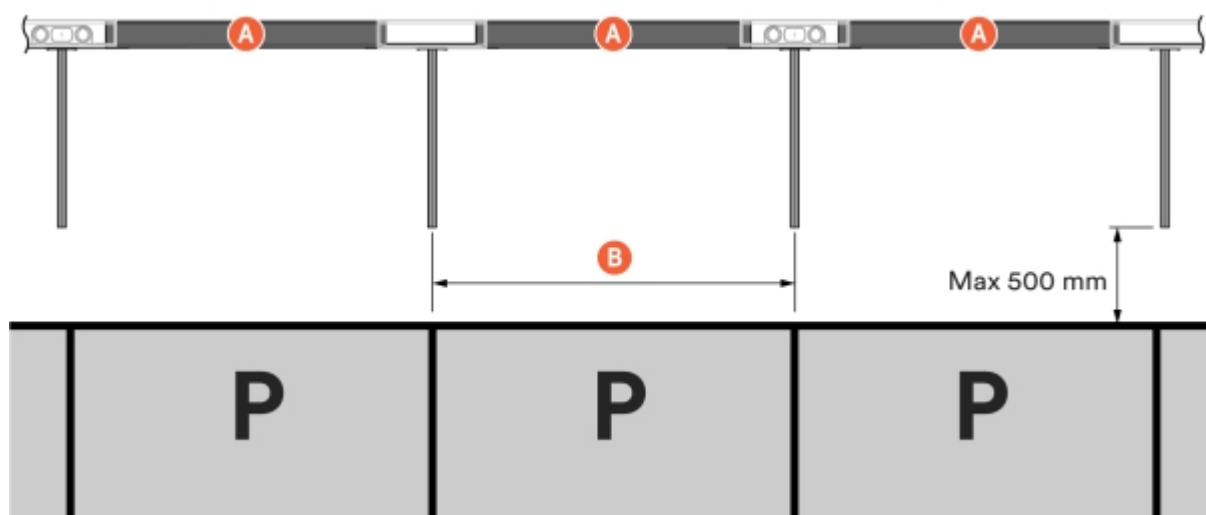





Image 11: Foundation positioning

A ConnectBar length

B Nominal parking width

2 Install post foundations (ground screw, ground spike, PoleBase or concrete foundation) with a hole diameter of 60 mm.

-  **Caution!** When securing the pole using ground screws or PoleBase, the supplied MountingTube must be fitted to the pole to prevent it from deforming over time.
-  **Caution!** When securing the pole using ground spike 3002, fixing plate 40102 must be used.
-  **Caution!** When mounting the poles with concrete foundations, we recommend the Saferoad 60/500 model (600500 FundSafeR 60/500).
-  **Caution!** PoleBase pole mounts must only be installed in concrete and must be secured using an expansion bolt. PoleBase must **not** be installed directly in asphalt.

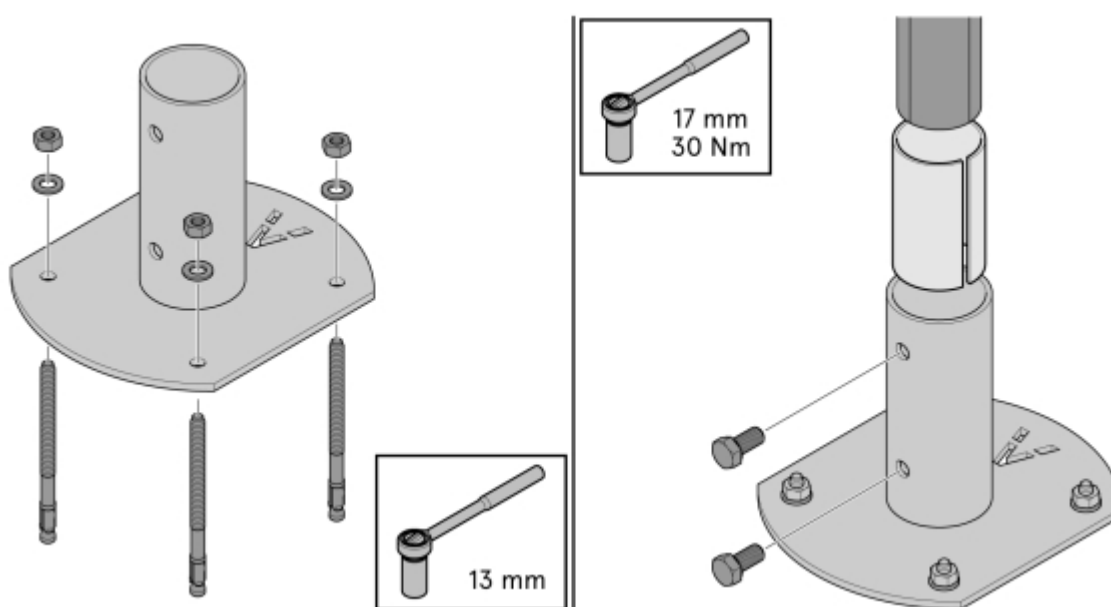

Image 12: PoleBase installation

3 Determine ConnectBar height.

- 3.1 When SmartHub is installed under ConnectBar, the maximum pole height for the two nearest poles at the central charging cabinet is 960 mm (with SmartHub Base standing on the ground). The minimum post height at the central charging cabinet is 860 mm (SmartHub Base buried 100 mm).

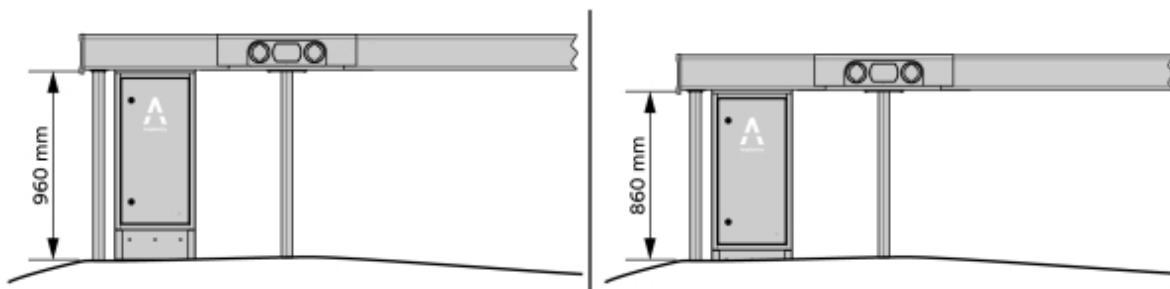

Image 13: ConnectBar height



**Caution!**

If the SmartHub Base is not buried, it must be secured to keep SmartHub stable.

For all other poles, the maximum height is 1000 mm and the minimum height is 600 mm.

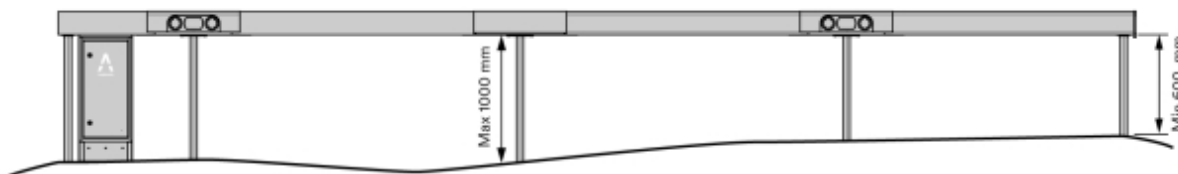

Image 14: ConnectBar height



**Keep in mind!**

The maximum forward/backward movement should be no more than  $\pm 10$  mm when a load of 10 kg per metre of post is applied (see **Image 18**).

- 3.2 When SmartHub is mounted on GroundBase as a freestanding unit, the maximum post height is 1000 mm and the minimum is 600 mm.

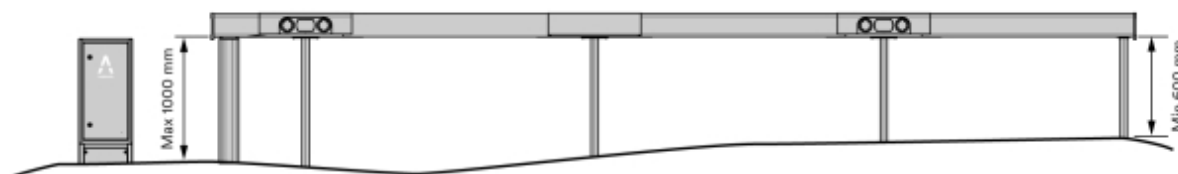

Image 15: ConnectBar height

- 4 Cut the poles to the desired length using a crosscut saw or band saw. The poles are supplied in lengths of 1450 mm.



**Keep in mind!**

If ConnectBar is to be installed at a later date, the poles are left uncut and unmounted to facilitate later installation.

- Wash the poles before cutting.
- Cut with a sharp blade.

- 5 Turn the poles so that the cut ends face downwards in the ground spike/screw/foundation.



**Caution!**

The pole may become scratched if handled carelessly when being inserted into or removed from a spike, screw or foundation.

- 6 When using screw connections, PoleSleeve must be fitted to prevent long-term deformation.

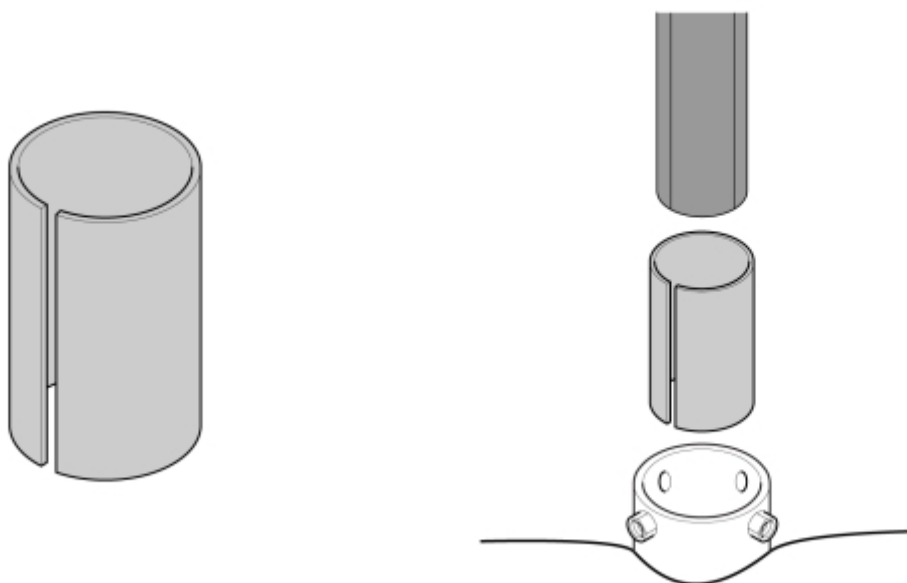

- 7 Turn the pole so that it faces the car park.

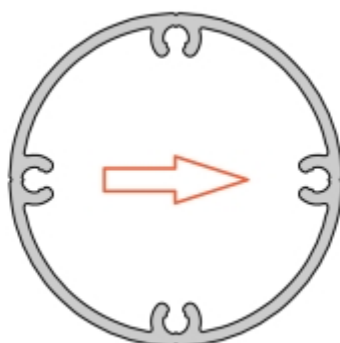

Image 16: Position of the pole in relation to the car park

- 8 Mark out the poles and secure them in the ground anchorages.
- It is important that the poles reach the bottom of the foundation.
  - For extra stability, use setting sand to fill the gap between the pole and the foundation.
- 9 Check that the poles provide a flat line to mount ConnectBar on. The maximum permissible misalignment per section is 10 mm in total between the ends.

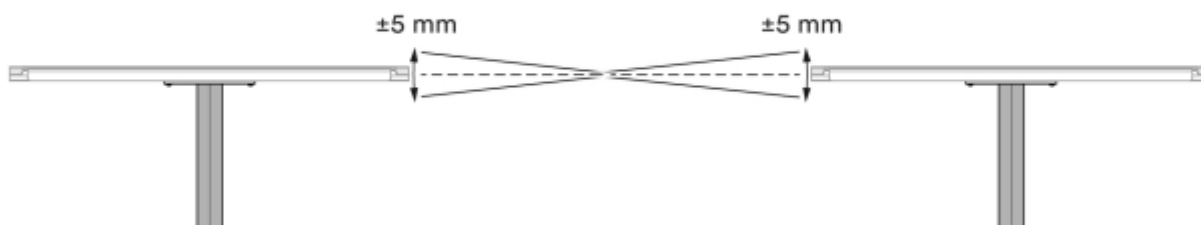

Image 17: Maximum misalignment

- 10 Check that the poles are straight using a string; adjust if necessary.
- Forward/backward tilt must not exceed  $\pm 10 \text{ mm}$  when a load of 10 kg per metre of post is applied.
  - Lateral tilt must not exceed  $\pm 10 \text{ mm}$  when a load of 10 kg per metre of post is applied.
  - The combined tilt of two adjacent poles shall not exceed 15 mm per metre of pole.

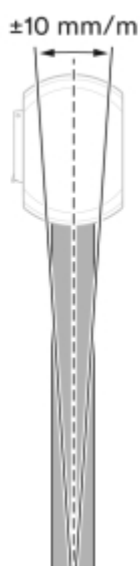

Image 18: Maximum tilt – front and back

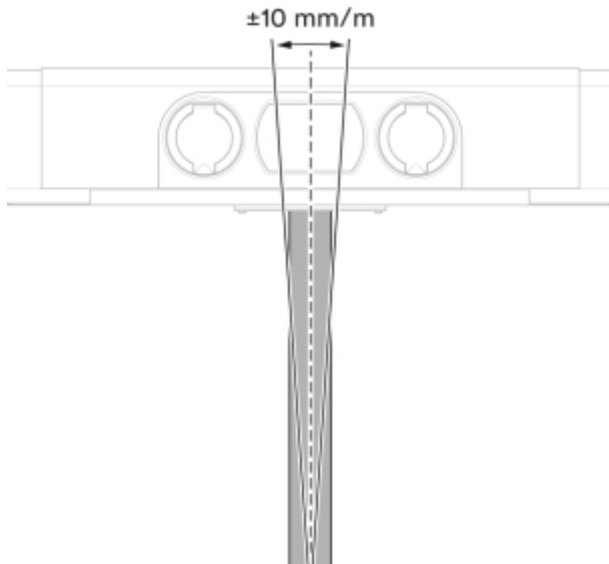

Image 19: Maximum tilt – sideways

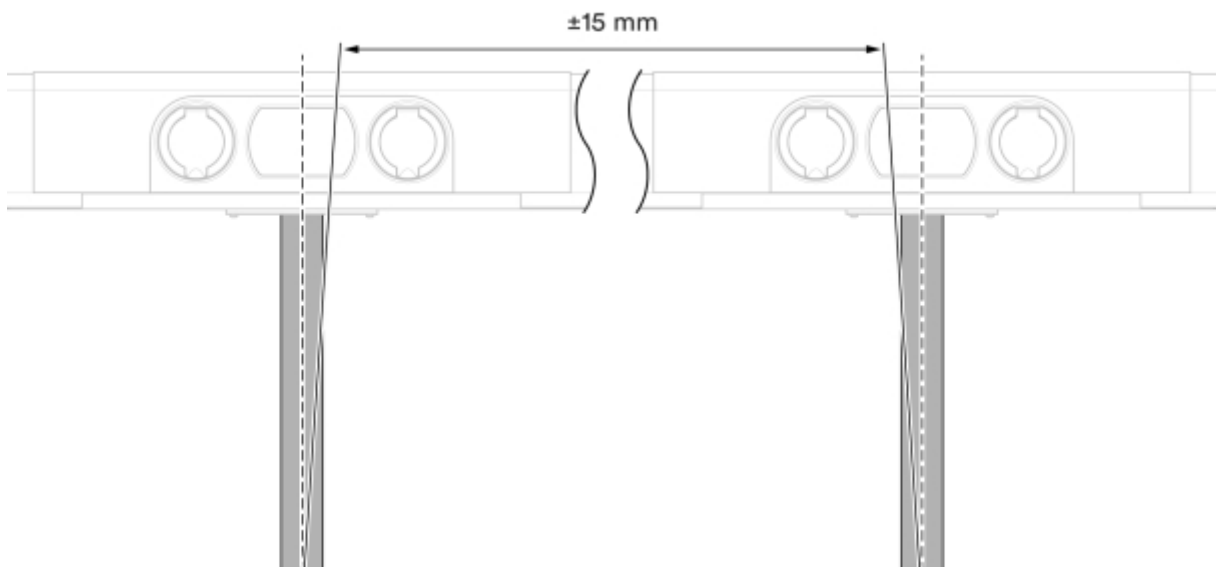

Image 20: Maximum tilt – total

## 11 Check the stability.

- The maximum forward/backward movement should be no more than  $\pm 10$  mm when a load of 10 kg per metre of post is applied.

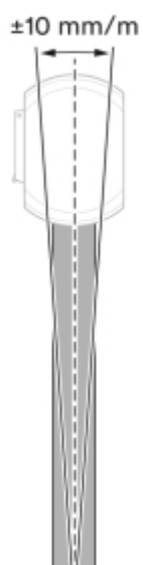

Image 21: Checking stability

## 12 Install mounting brackets on each post bracket.

**Keep in mind!**

Align the mounting bracket before securing the screw to the pole.

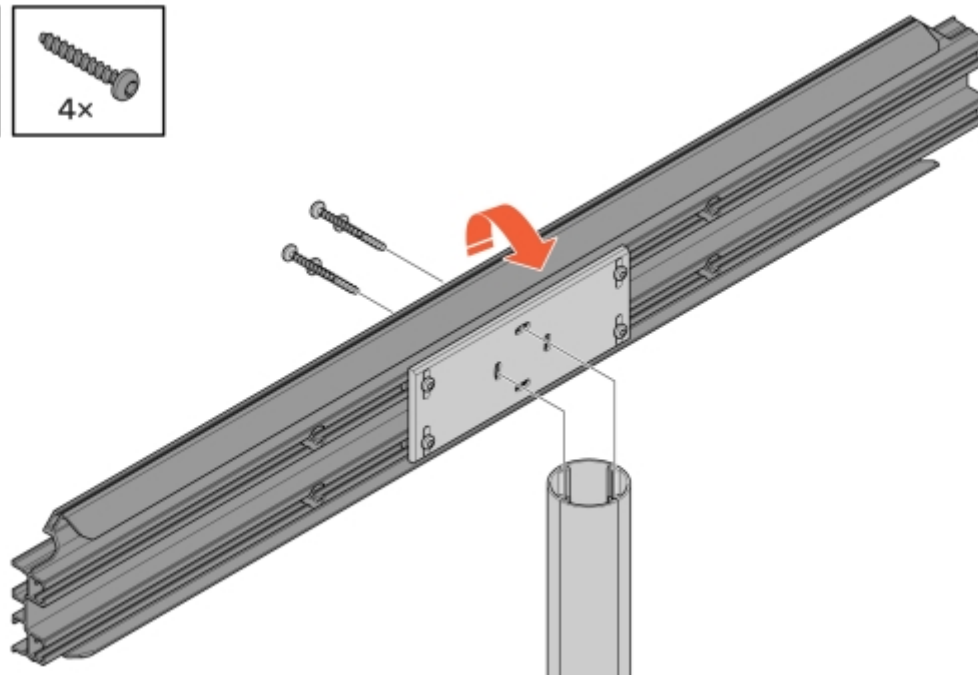
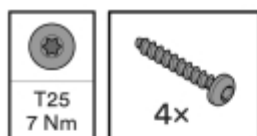

Image 22: Mounting bracket installation

**Caution!**

Post screws must be tightened with caution to avoid stripping the screws.

- 13 Align the mounting brackets and then secure the post bracket from below.

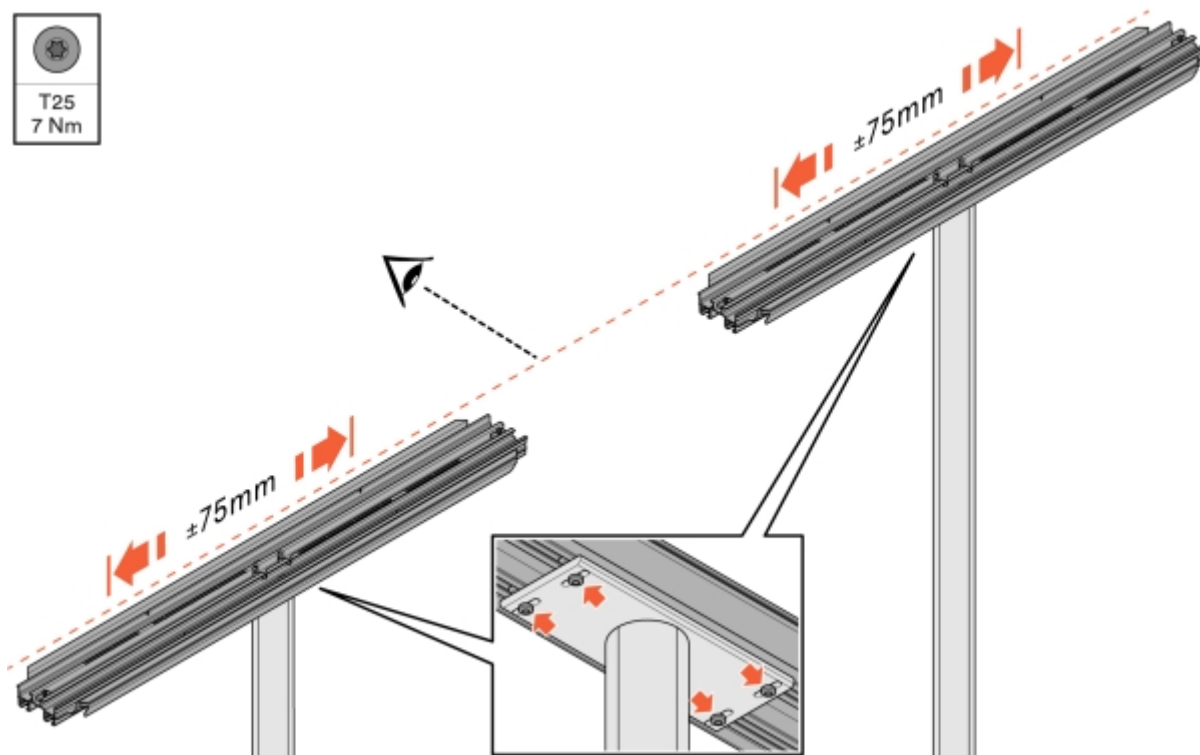

Image 23: Alignment and securing of mounting bracket

- 14 Install ConnectBar by sliding it onto the first bracket and then over onto the second bracket. Adjust ConnectBar along the brackets so that it is centred between the poles. Use the scales on the brackets as a guide.

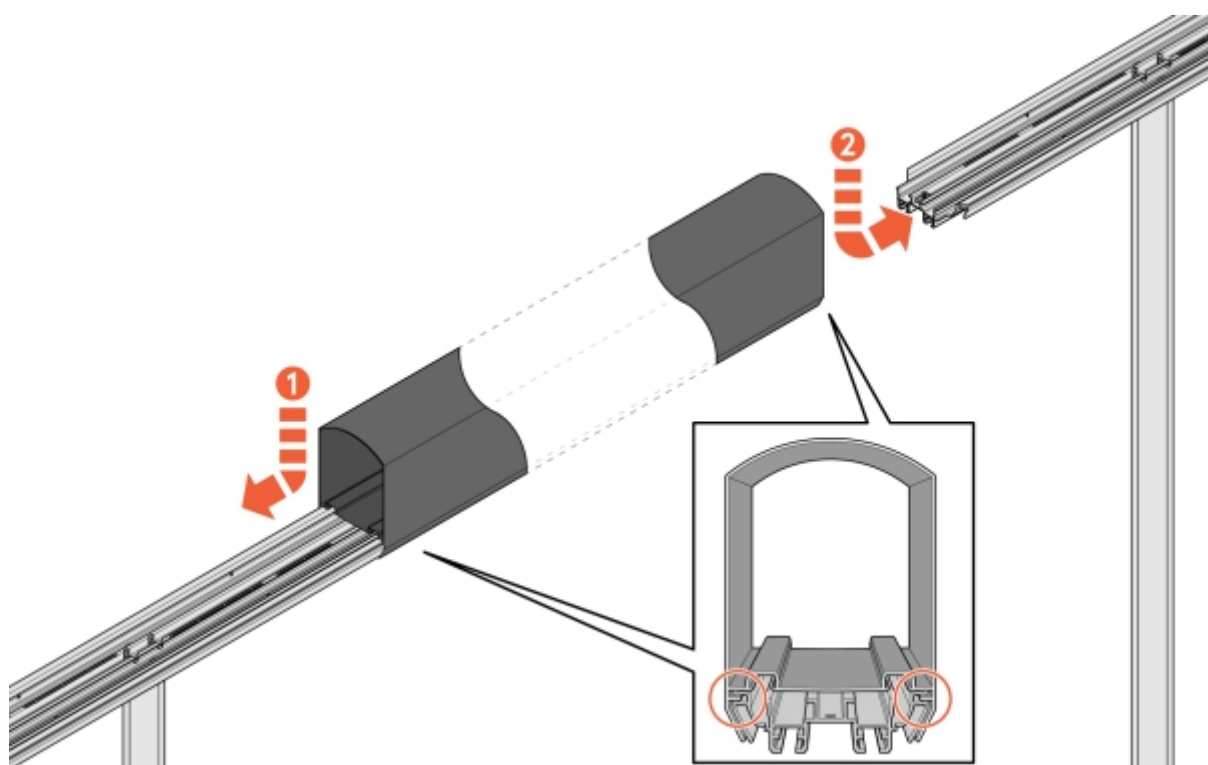

Image 24: ConnectBar installation

15 Check the positioning and make sure that ConnectBar is mounted in the tracks of the mounting bracket.

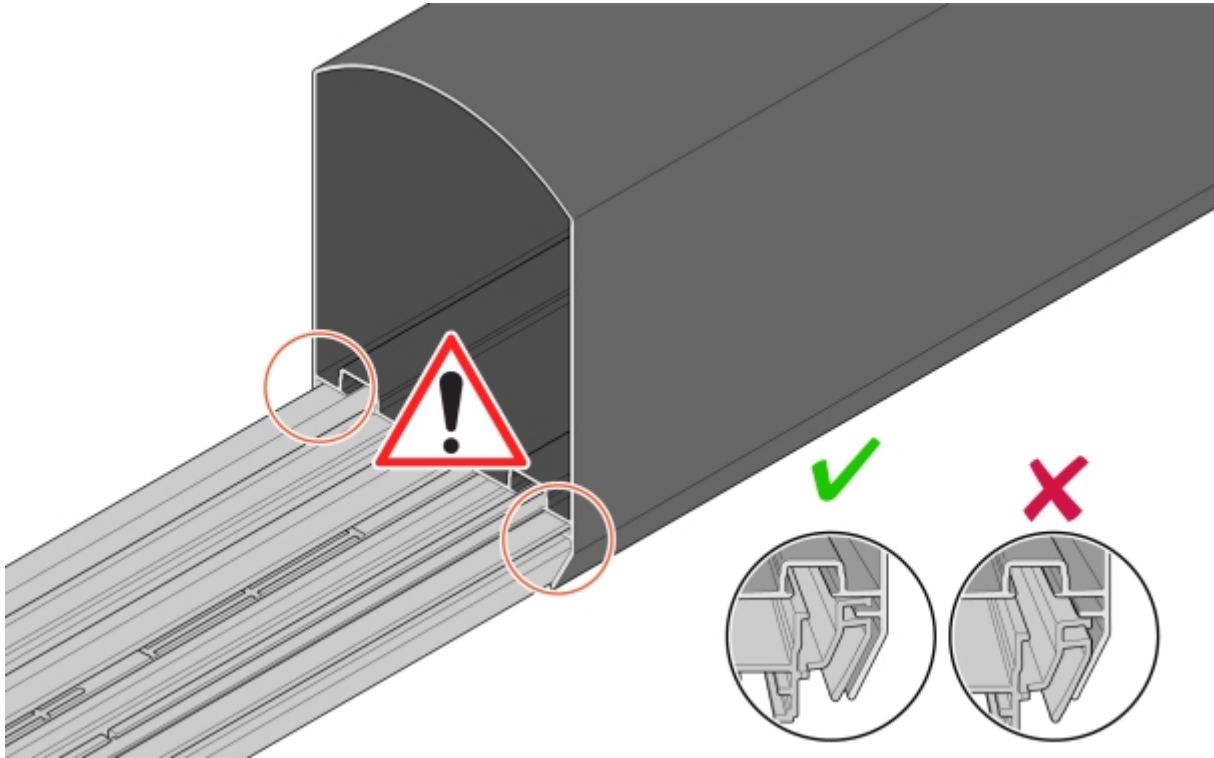

Image 25: Checking positioning and mounting

16 Adjust ConnectBar along the mounting brackets.

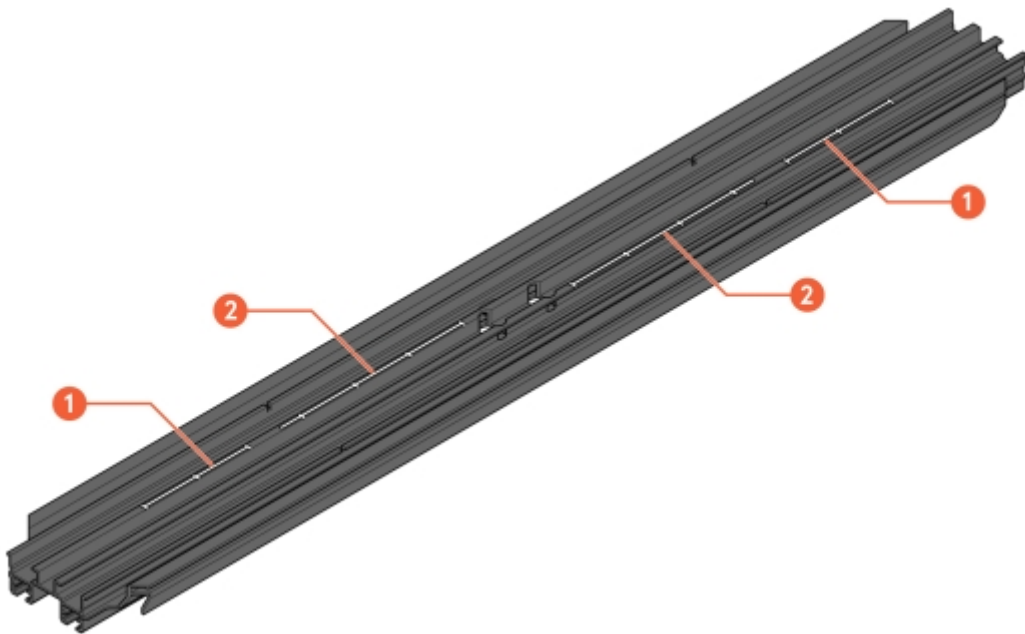

Image 26: Tracks for adjustment

1 Scale for adjustment with ChargePod

2 Scale for adjustment without ChargePod

17 Secure ConnectBar in the mounting bracket.

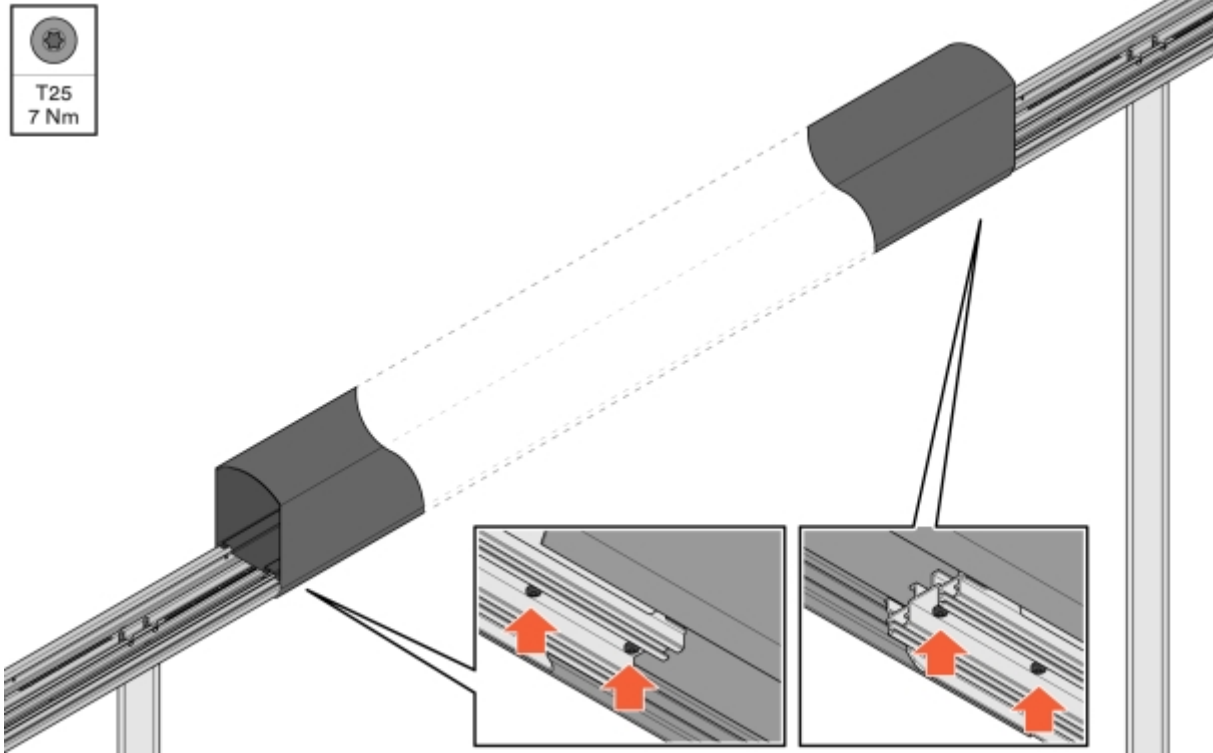

Image 27: Securing ConnectBar

18 Verify that ConnectBar is straight. The maximum permissible misalignment per section is 10 mm in total between the ends.

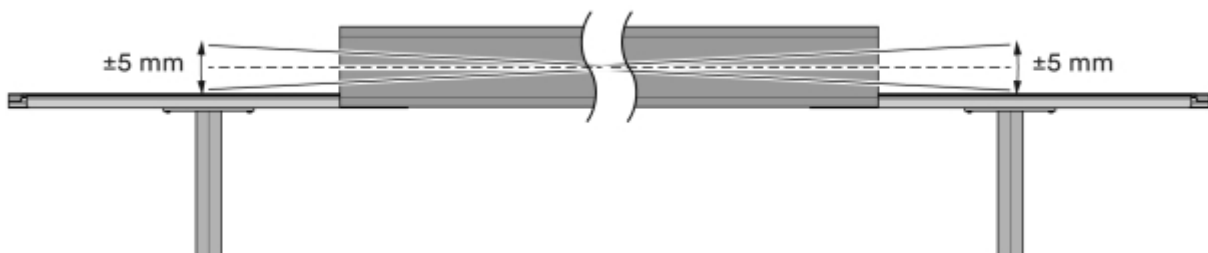

Image 28: Maximum misalignment

19 When installing lighting, route the LED strip through the profile.



**Keep in mind!**

The LED strip must be turned 90 degrees to fit in the slot on the bracket.

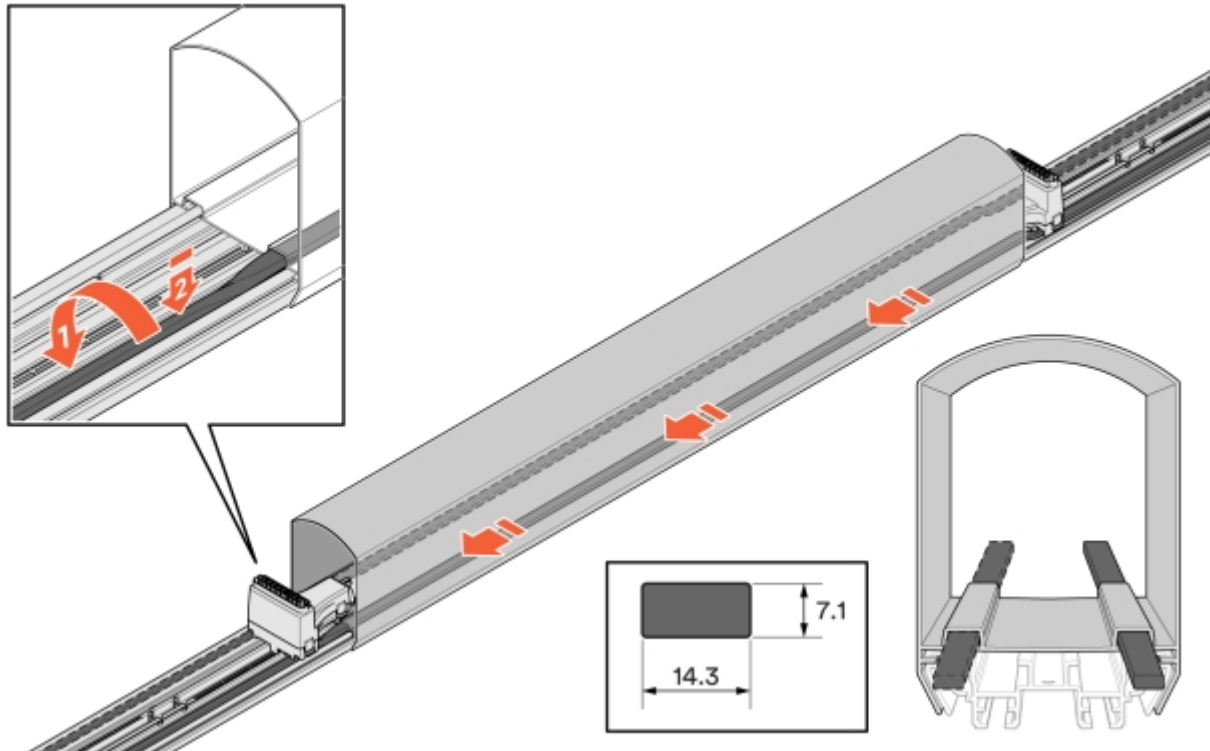

Image 29: LED installation

**20** Insert the cable into ConnectBar:**20.1** Insert a connector and attach it to the mounting bracket's mounting holes.

Image 30: Cable in ConnectBar

**20.2** If the cable is too long, create one loop of cable and then attach the second connector.

Image 31: Looped cable

21 Fit ChargePod straight down from above and secure it from underneath.

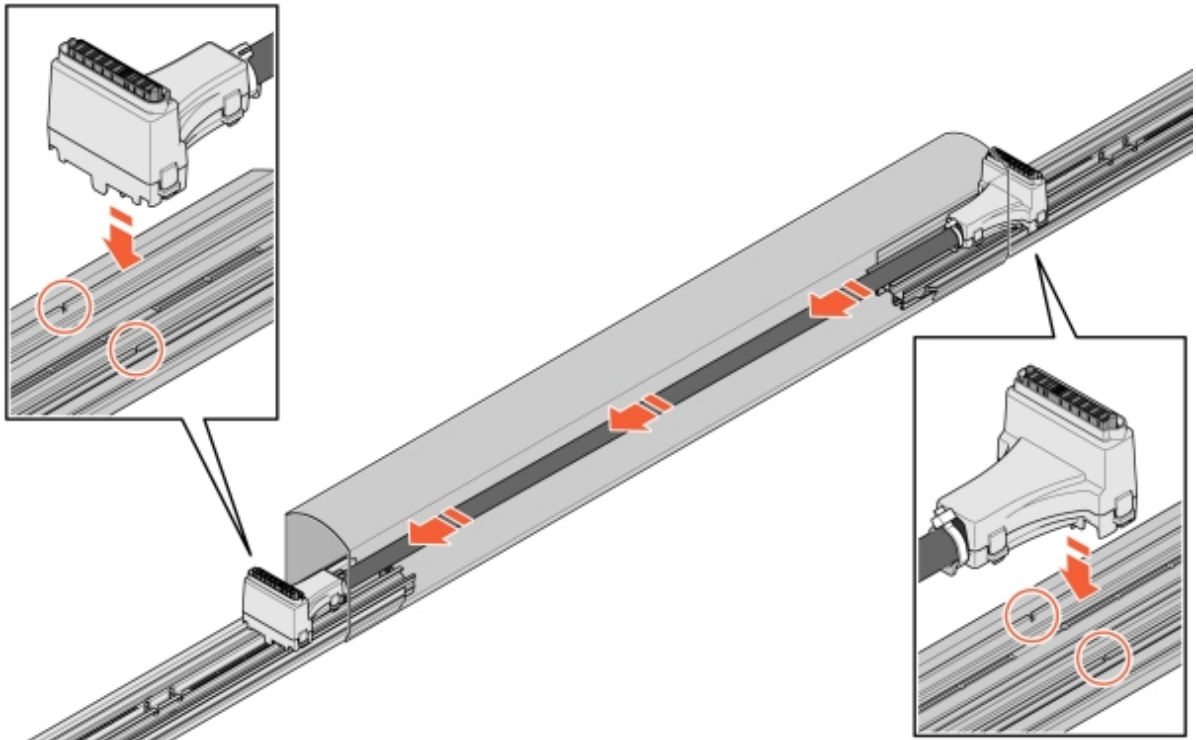

**Keep in mind!**

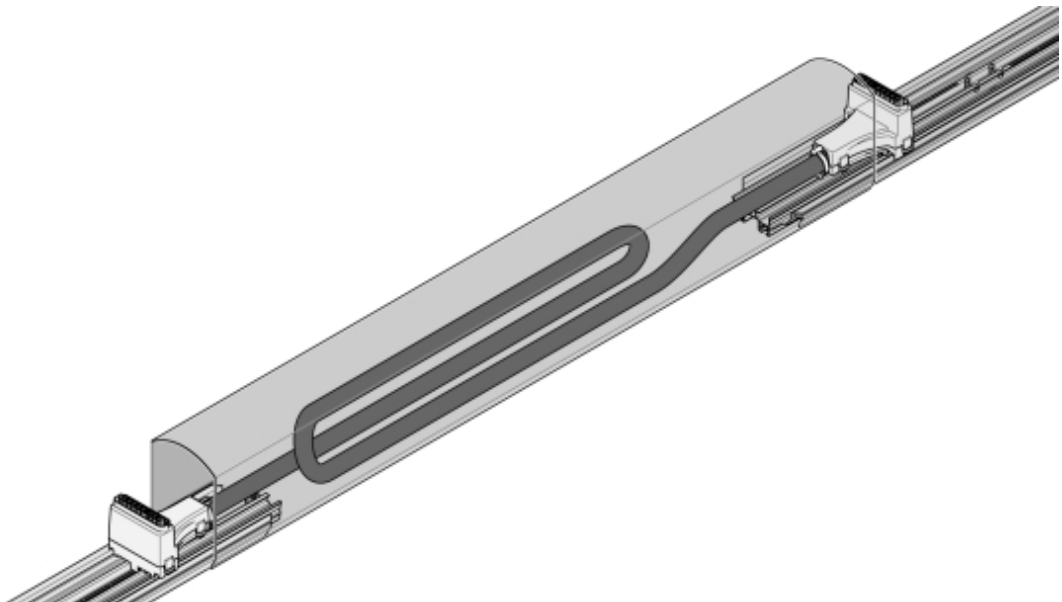
ChargePod is designed for fixed installation and may only be removed or reinstalled for repair or replacement. Avoid inserting and removing ChargePod unnecessarily.

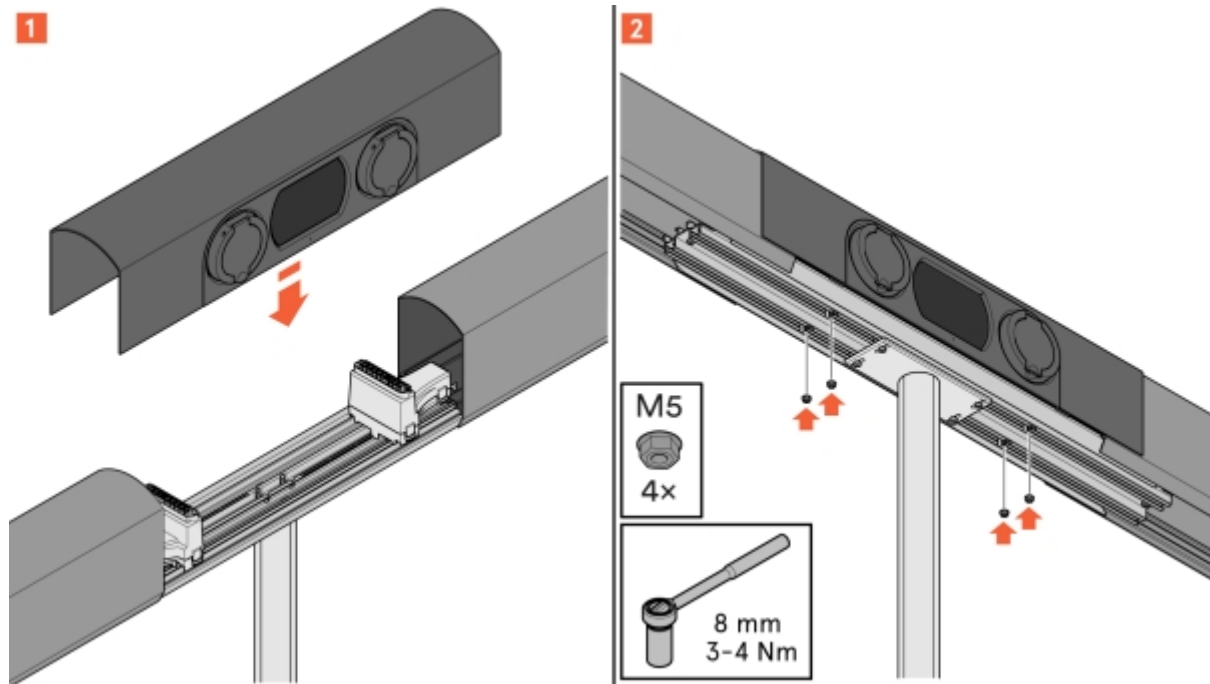

Image 32: ChargePod installation



**Caution!**

Install ChargePod straight down from above, avoiding tilting ChargePod.

## Install ConnectCover for single-sided power bar

- 1 Place ConnectCover over the hole.

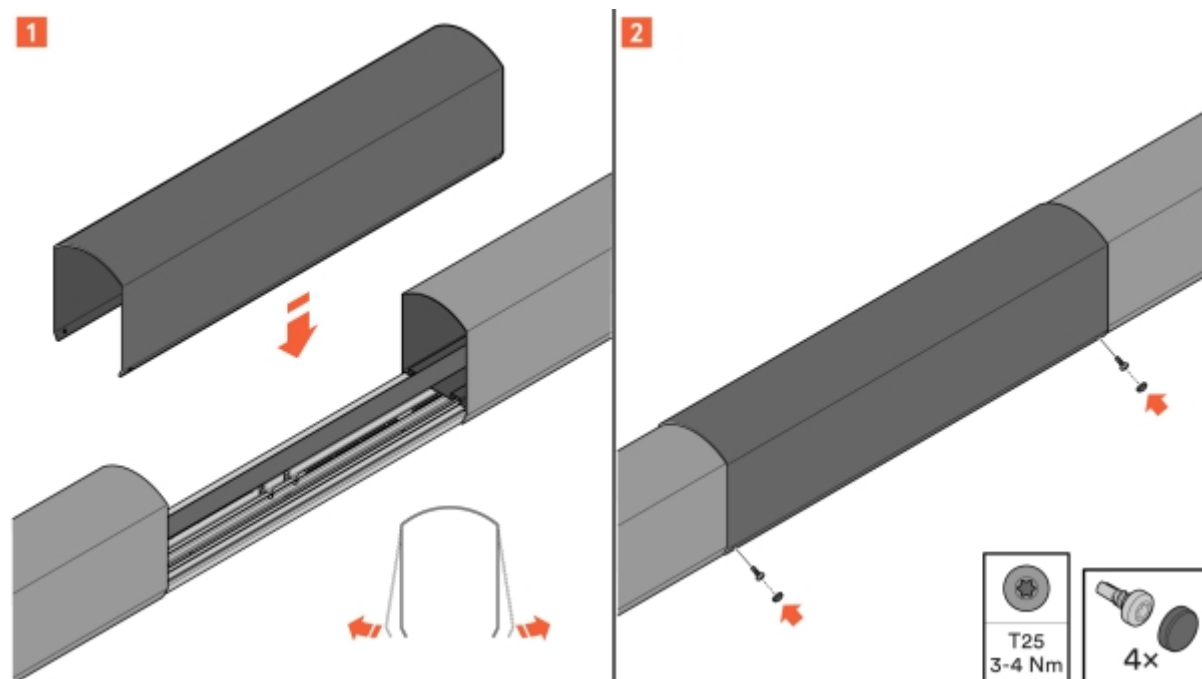
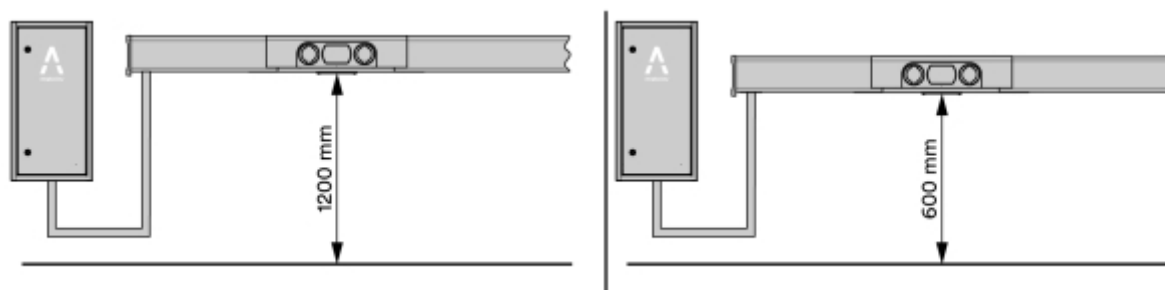

Image 33: ConnectCover installation

- 2 Screw the ConnectCover into place using the screws provided.

## Mounting ChargePod and ConnectBar on wall

- 1 When SmartHub is mounted on a wall, the recommended maximum height to the bottom edge of WallBracket Set is 1200 mm and the recommended minimum is 600 mm.



2 Install wall brackets at the intended ChargePod mounting point.

- The wall brackets are an L-profile screwed to the wall.
- Choose fasteners based on the type of surface.

Check Section 5.4 "Ranges of ConnectBar lengths available", **page 17** for the recommended width between wall brackets.

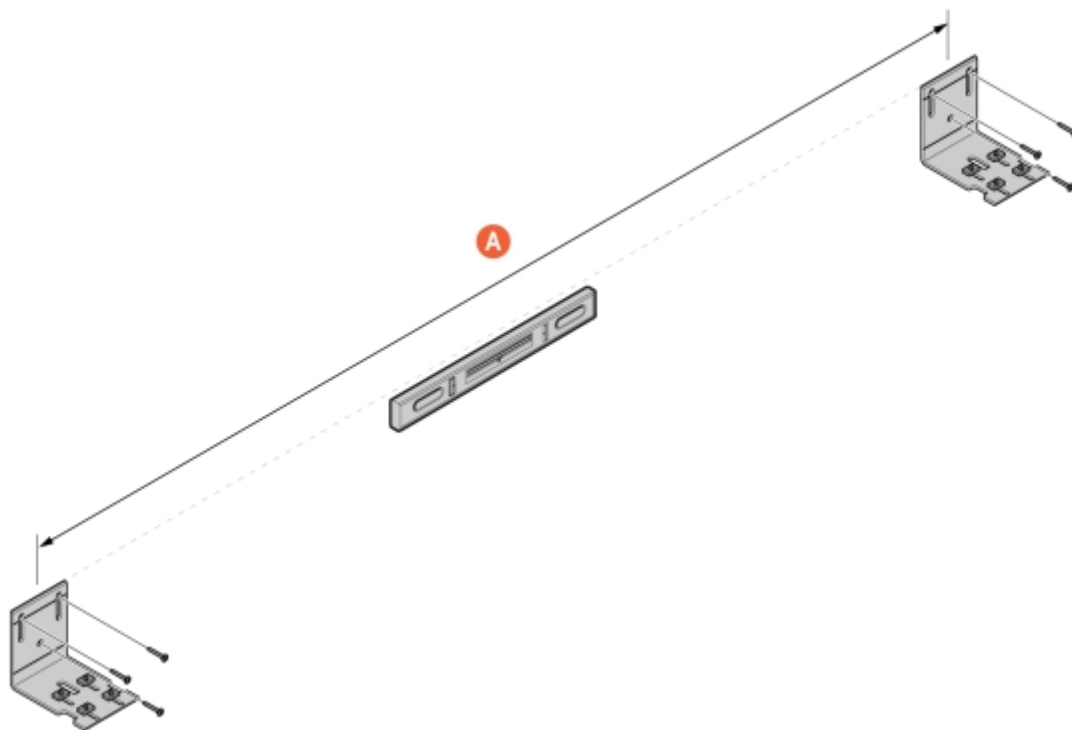

Image 34: Wall bracket installation

A ConnectBar length

3 Install mounting brackets on each wall bracket.

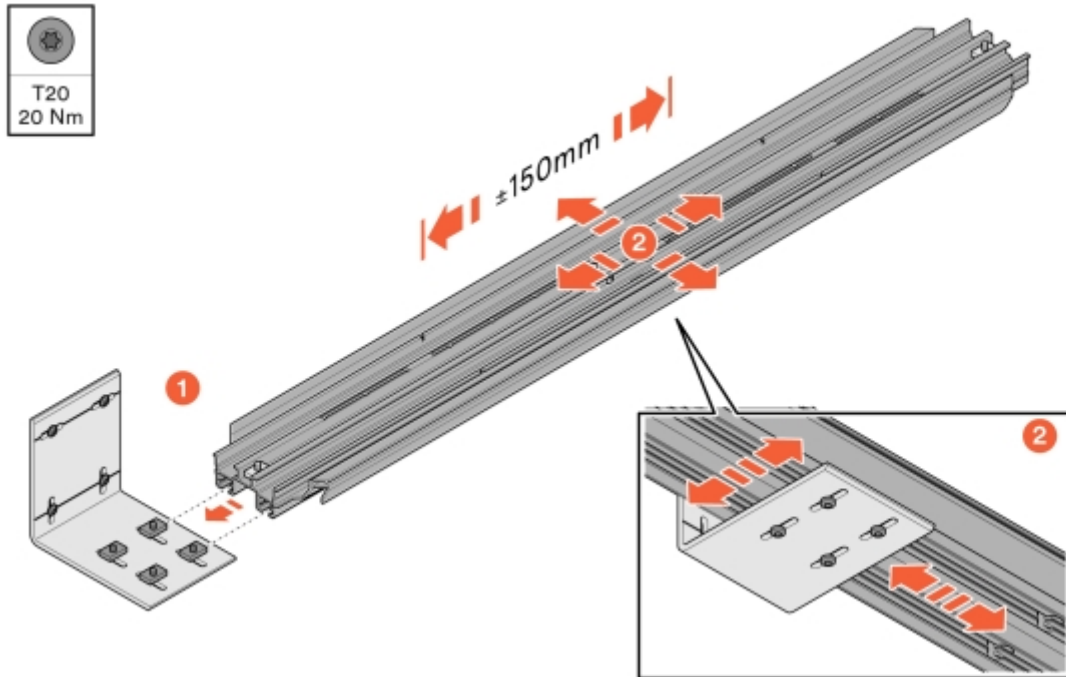

Image 35: Mounting bracket installation

4 Align the mounting brackets and then secure the wall bracket from below.

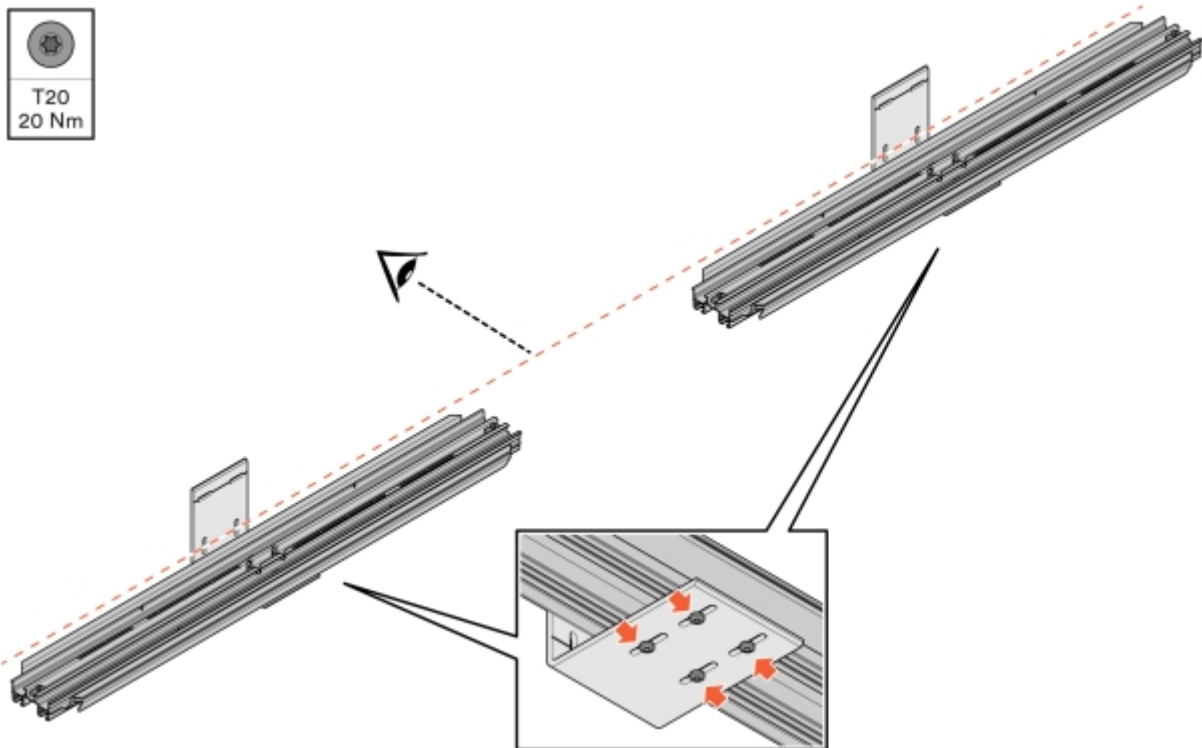

Image 36: Alignment and securing of mounting bracket

5 Install ConnectBar.

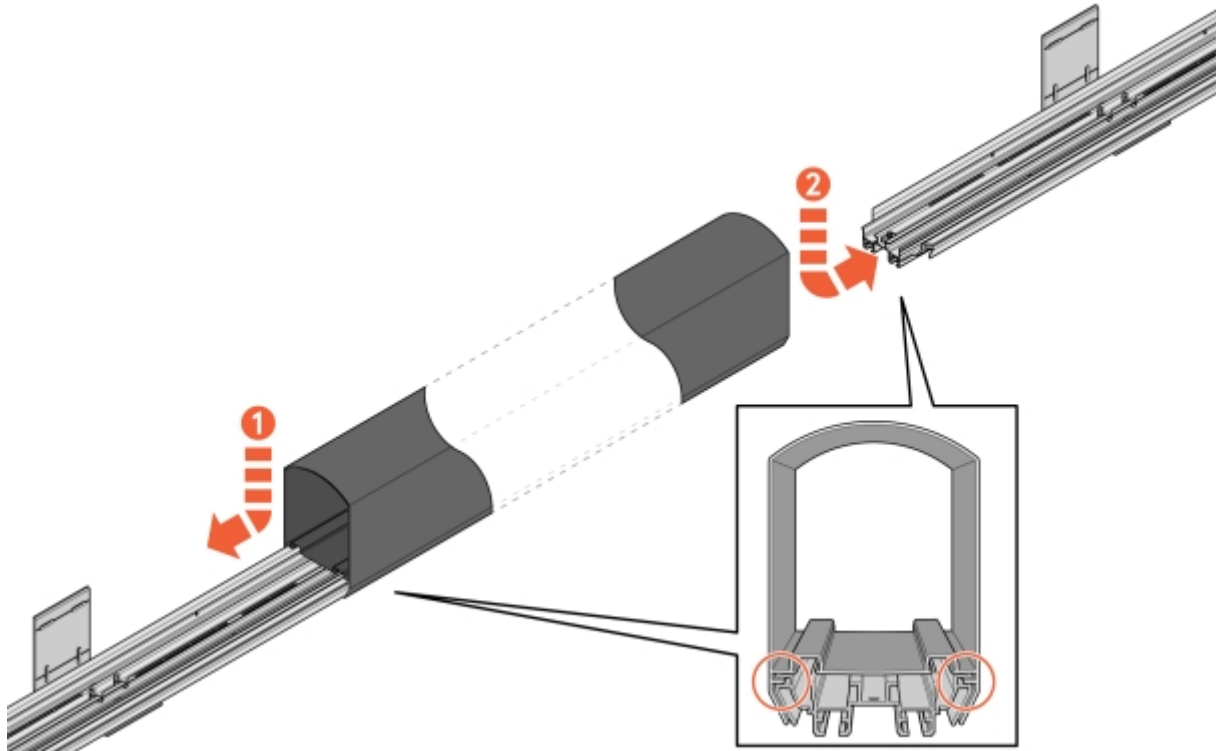

Image 37: ConnectBar installation

6 Check the positioning and make sure that ConnectBar is mounted in the tracks of the mounting bracket.

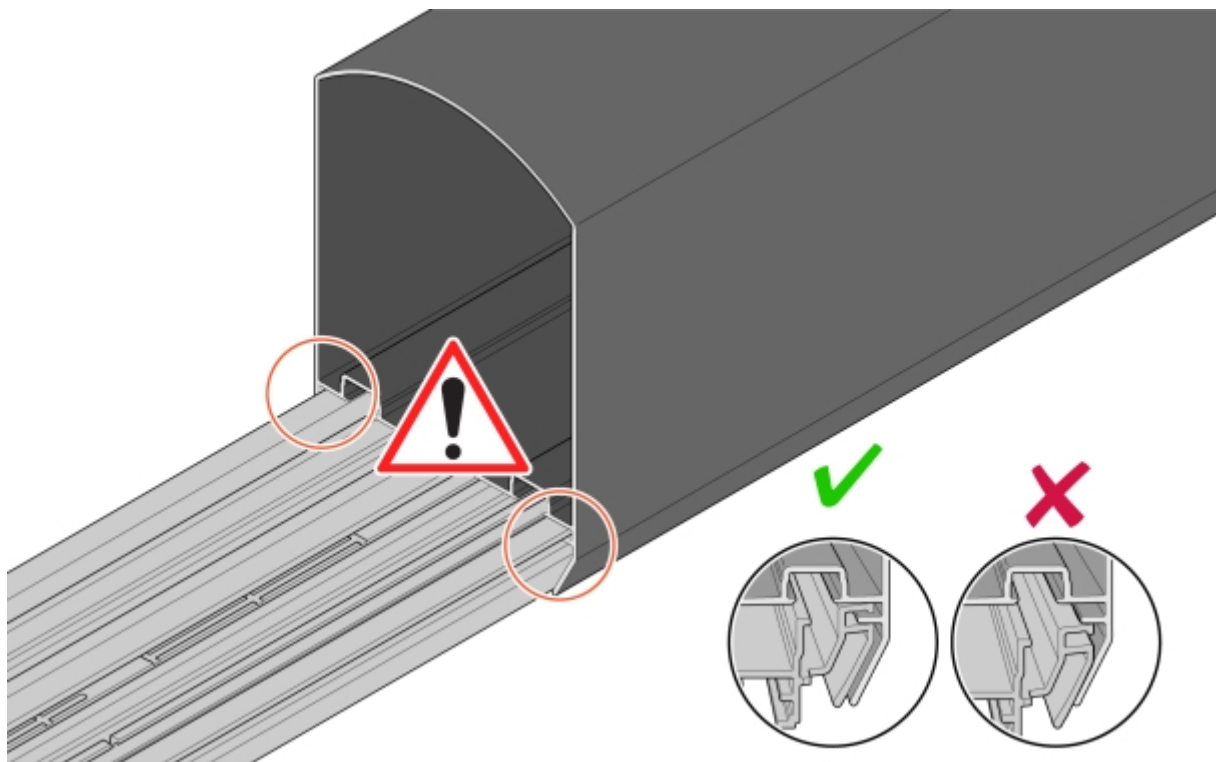

Image 38: Checking positioning and mounting

7 Adjust ConnectBar along the mounting brackets.

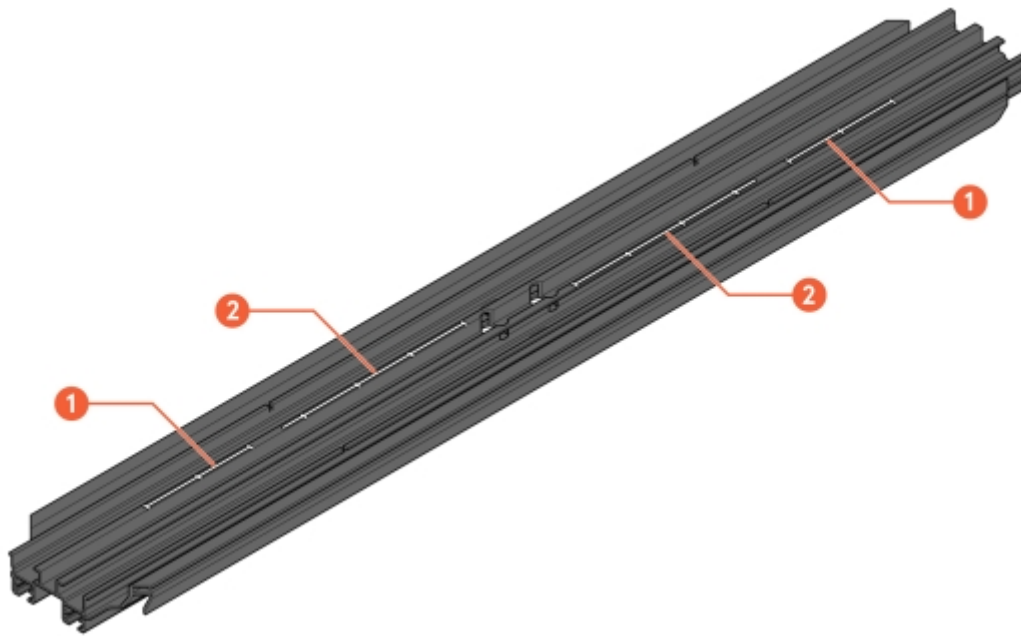

Image 39: Tracks for adjustment

1 Scale for adjustment with ChargePod

2 Scale for adjustment without ChargePod

8 Secure ConnectBar in the mounting bracket.

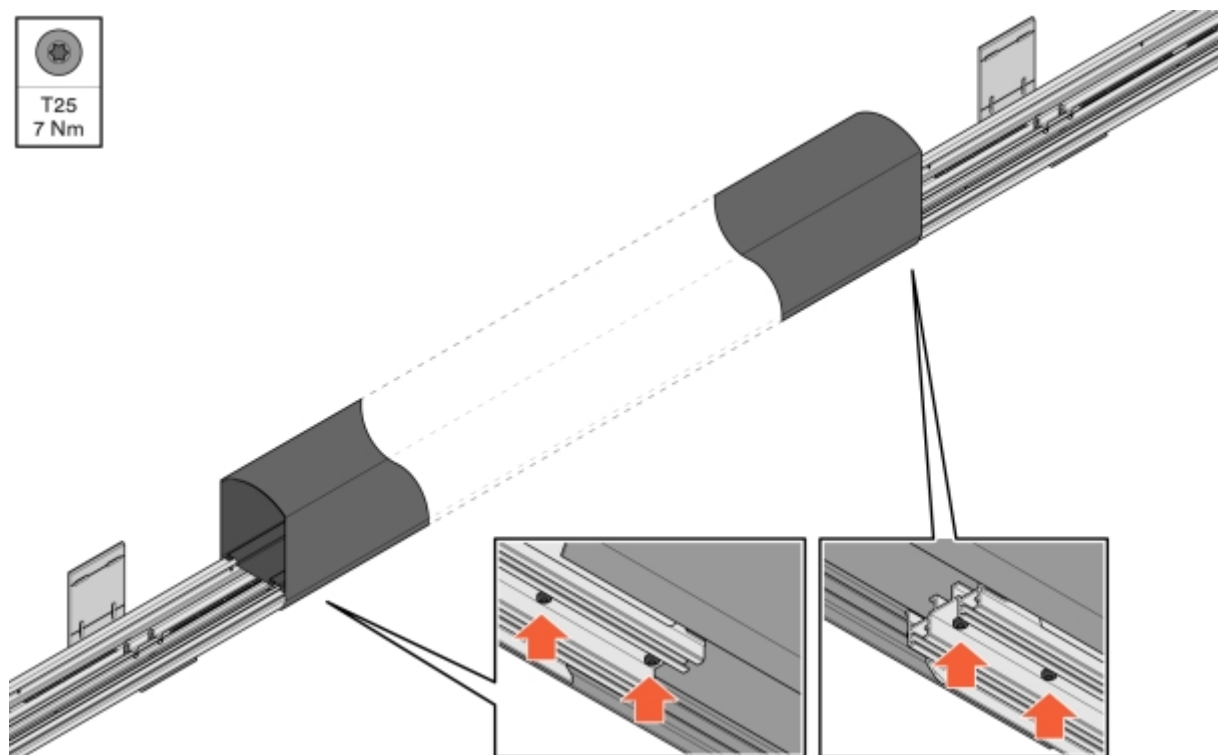

Image 40: Securing ConnectBar

9 Verify that ConnectBar is straight.

- The maximum permissible misalignment per section is 2 mm in total between the ends.

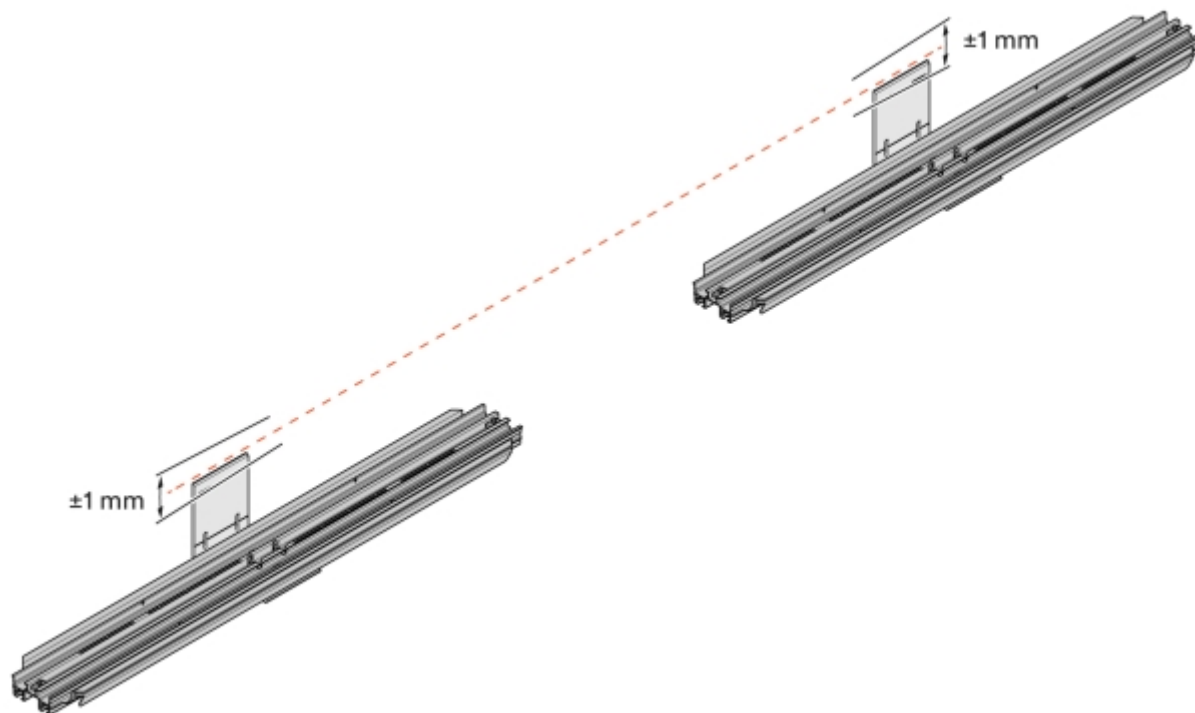

Image 41: Checking straightness

10 When installing lighting, route the LED strip through the profile.



**Keep in mind!**

The LED strip must be turned 90 degrees to fit in the slot on the bracket.

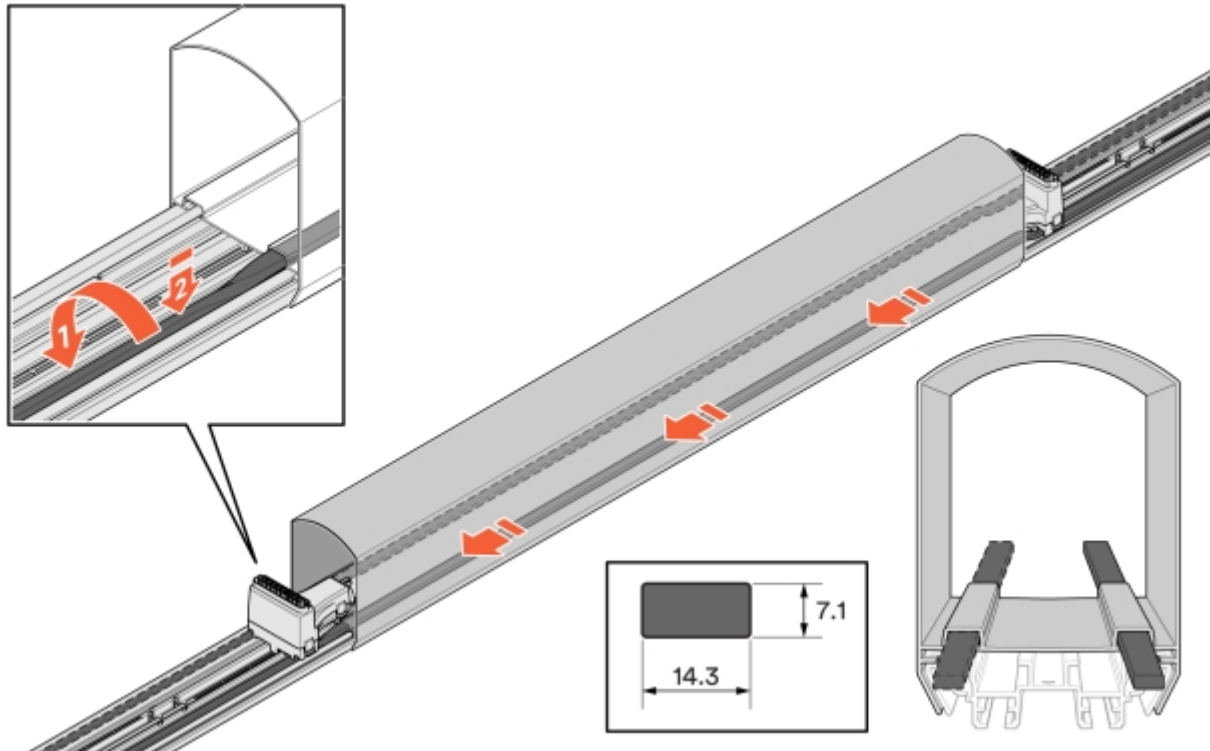

Image 42: LED installation

11 Insert the cable into ConnectBar:

11.1 Insert a connector and attach it to the mounting bracket's mounting holes.

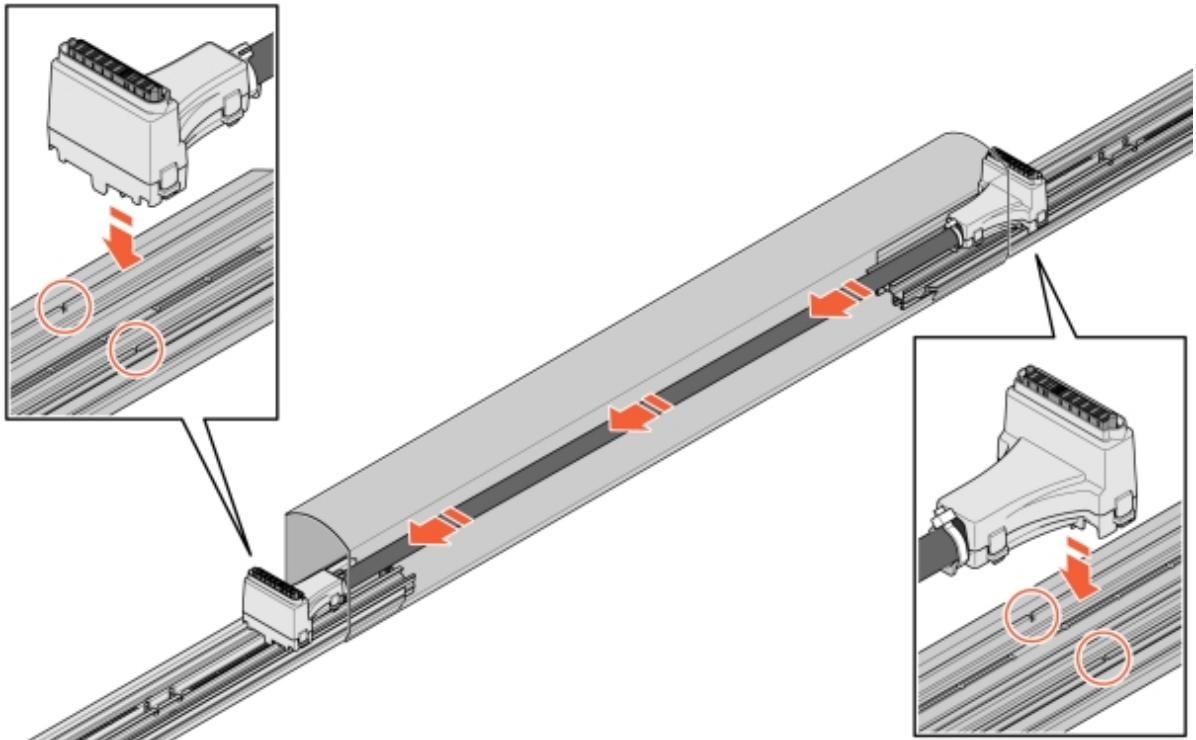

Image 43: Cable in ConnectBar

11.2 If the cable is too long, create one loop of cable and then attach the second connector.

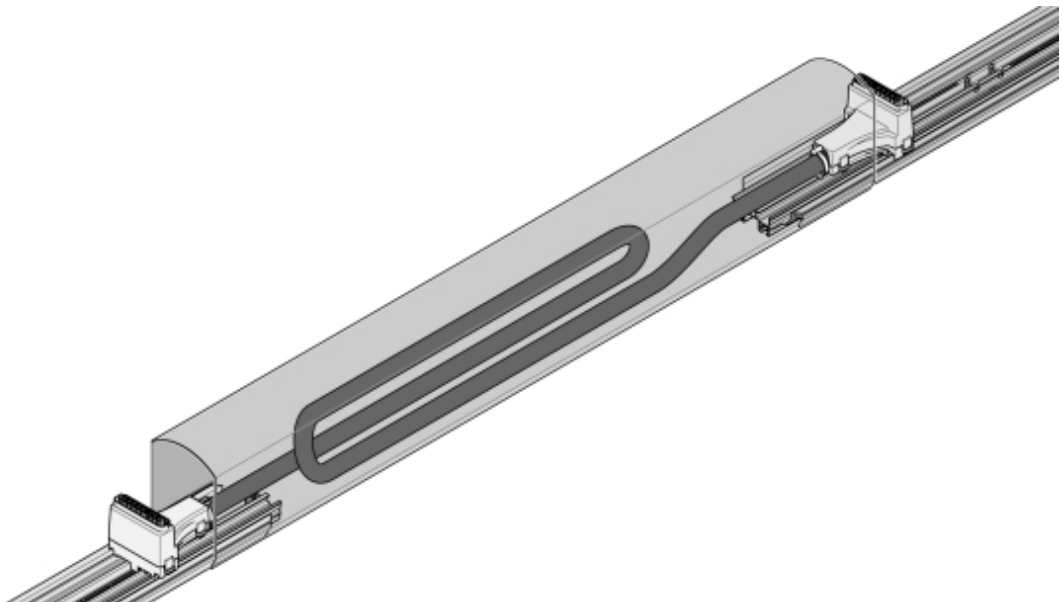

Image 44: Looped cable

- 12 Remove the protective covers from the connectors, mount ChargePod straight from the top down and secure from underneath.



**Keep in mind!**

ChargePod is designed for fixed installation and may only be removed or reinstalled for repair or replacement. Avoid inserting and removing ChargePod unnecessarily.

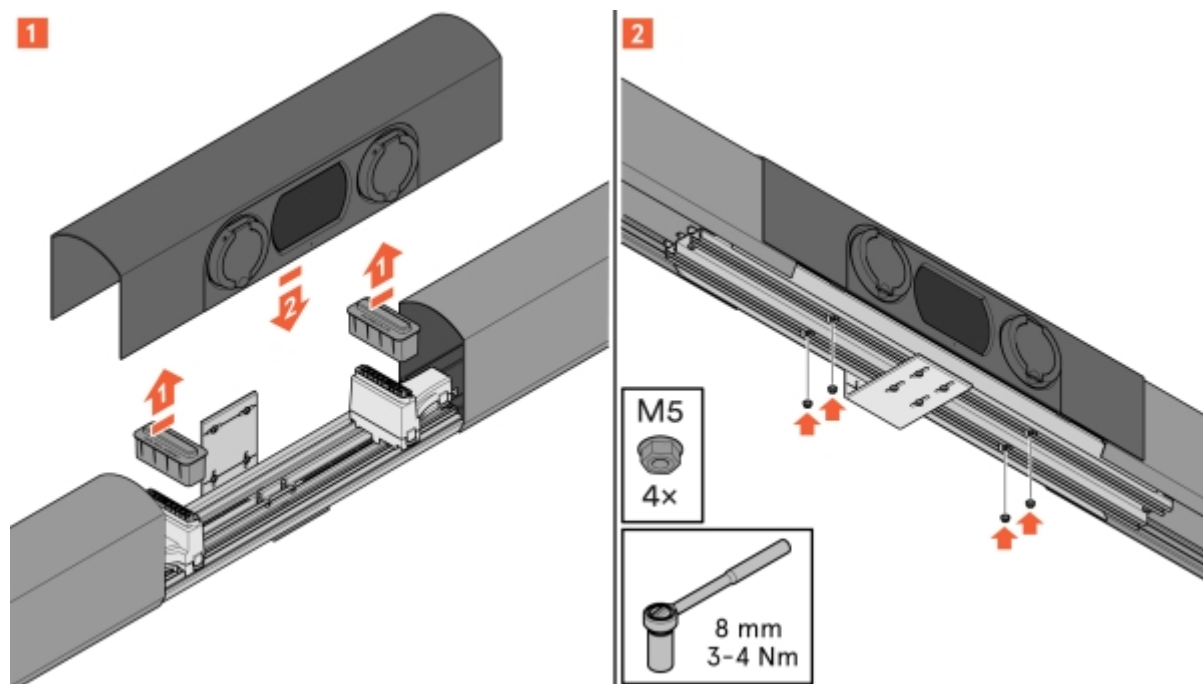

Image 45: ChargePod installation



**Caution!**

Install ChargePod straight down from above, avoiding tilting ChargePod.

- 13 Check that there are no gaps around the display.

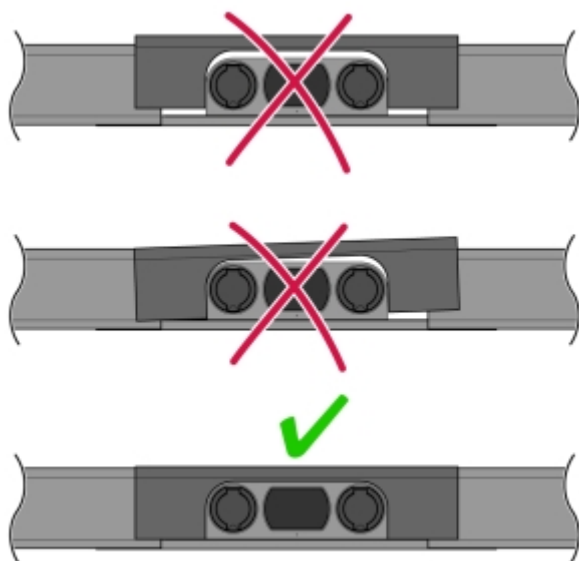

If there is a gap, it is most likely because ConnectBar is not properly mounted in the slots on the mounting bracket. See **Image 38**.

## Install ConnectCover for single-sided power bar

- 1 Place ConnectCover over the hole.

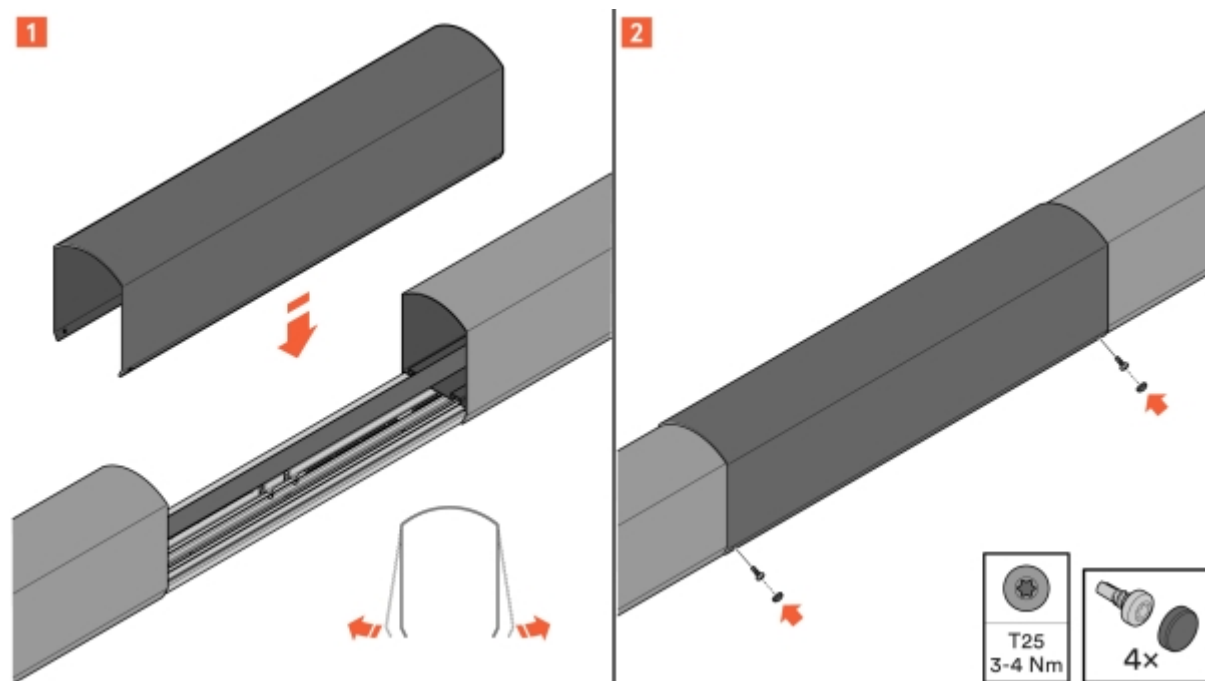

Image 46: ConnectCover installation

- 2 Screw the ConnectCover into place using the screws provided.

## Install WallConnection

### Cables

To ensure proper functionality and long-term operation, we recommend the following cables:

- **Power cable:** Aceflex 5G16
- **Data cable:** CAT6 UTP/FTP, black
- **Signal and 24 V cable:** Aceflex 5G1.5

- 1 Make sure that the ConnectBar is correctly mounted, aligned, and secured.

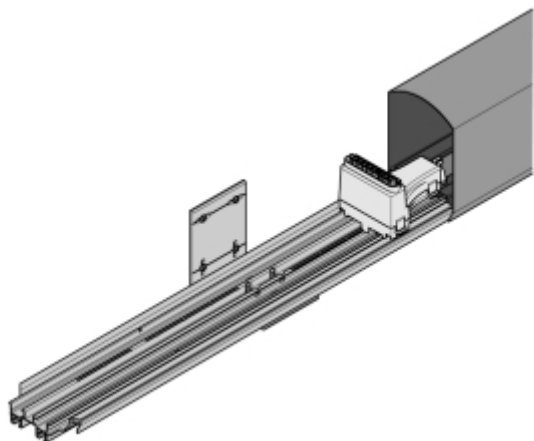
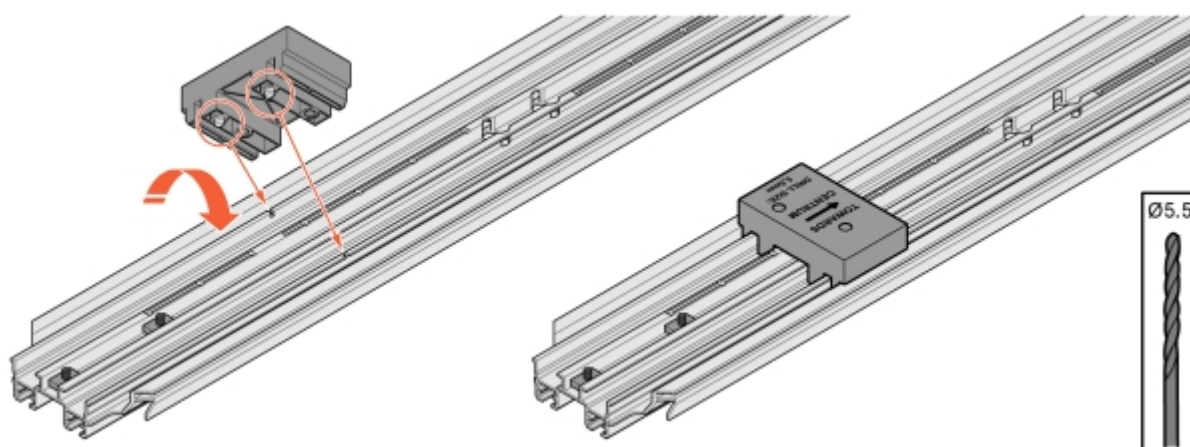

Image 47: Installed ConnectBar

- 2 Use the drilling template to drill two holes in ConnectBar for JunctionBox.



- 3 Remove the cover from JunctionBox.
- 4 Snap the bottom part onto the bracket.

5 Secure the lower section to the bracket using two screws in the new holes.

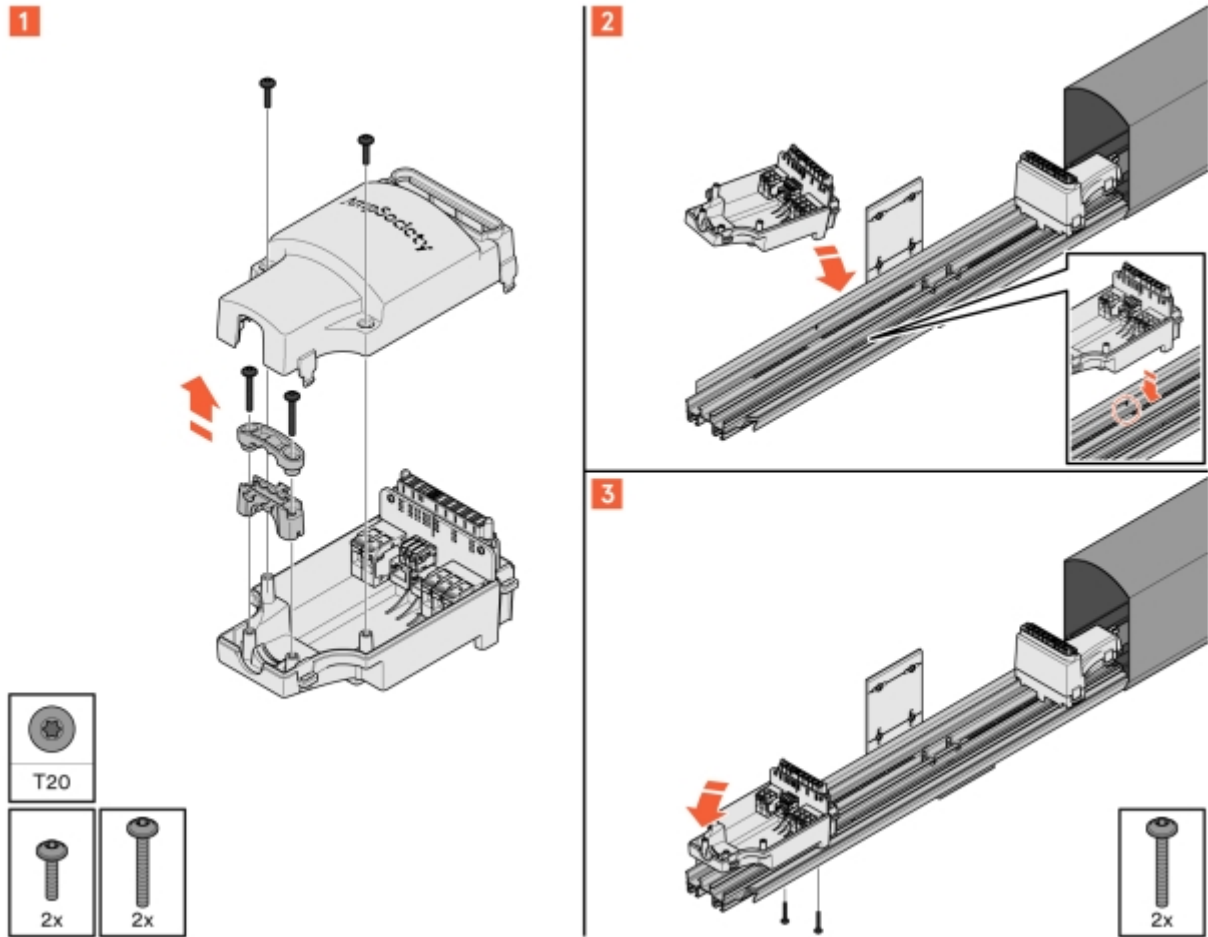

Image 48: JunctionBox installation

6 Check all cables before installation.

7 Install the power cable and secure it with the cable clamp.

8 Install the data cables, securing them with three cable ties and the second cable clamp.

9 Fit the cover and secure it with two screws.

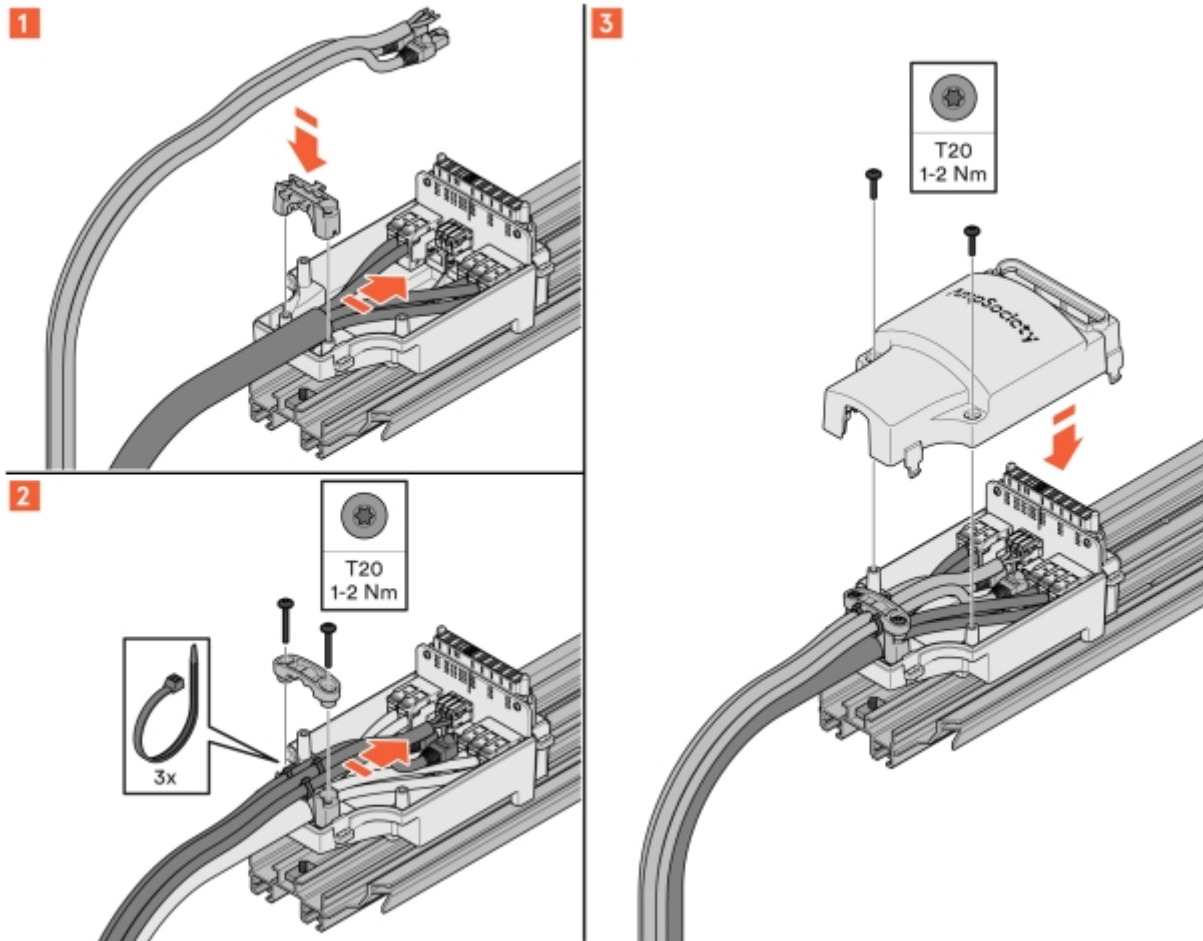

Image 49: Connecting JunctionBox

10 Mount CableBar on the mounting bracket.



**Keep in mind!**

When installing CableBar, be careful so as not to damage the cables.

11 Secure CableBar to the bracket with a screw.

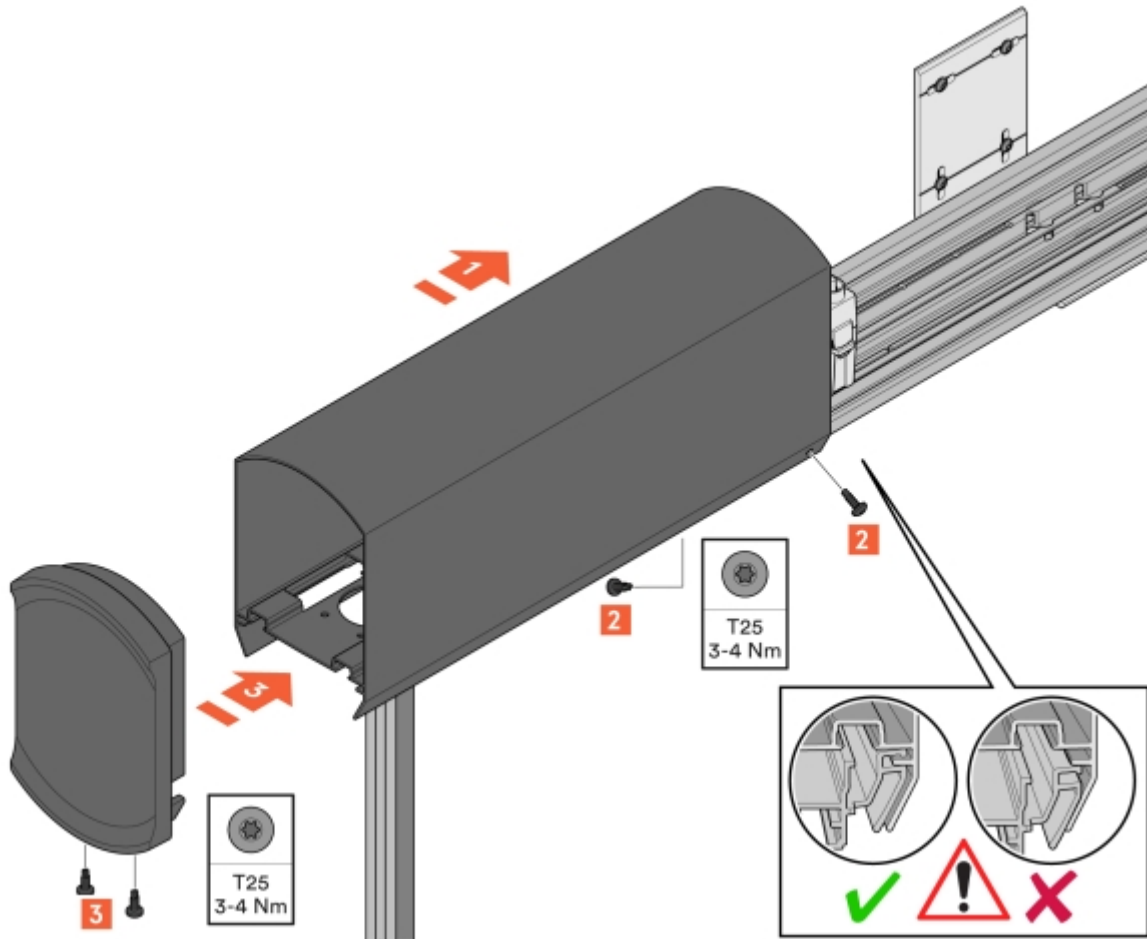

Image 50: CableBar installation

12 Place the drilling template over EndCap and screw the screws in loosely.

13 Remove the drilling template and tighten the screws to the specified torque.

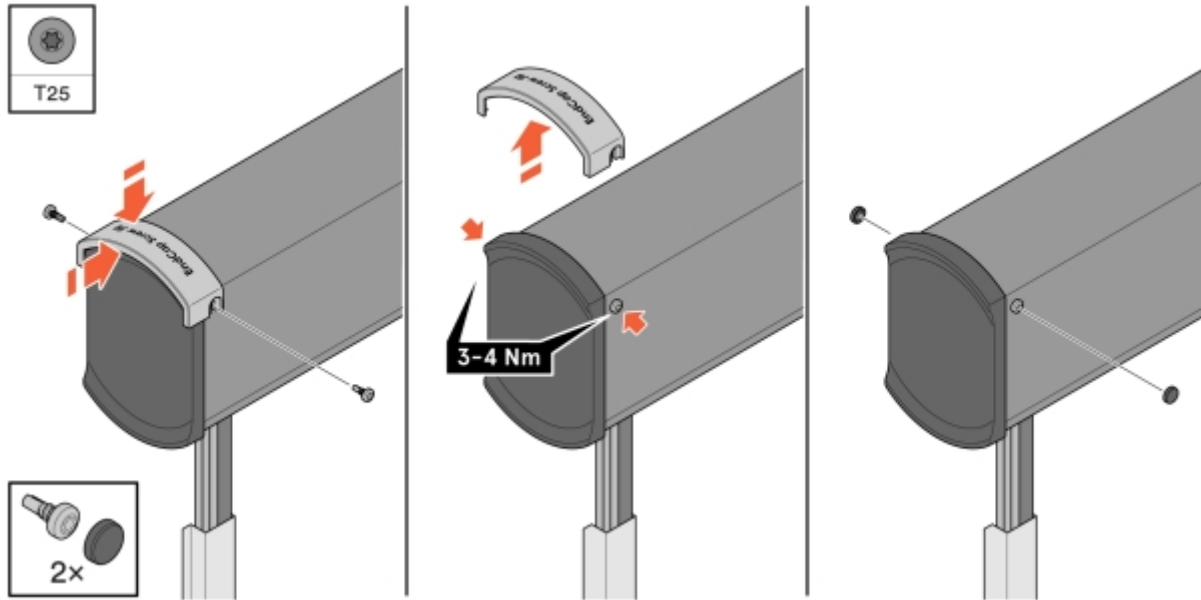

Image 51: EndCap installation

14 Secure all cables and cover with cable protection.

15 Position ChargePod and secure it with four nuts.



**Keep in mind!**

ChargePod is designed for fixed installation and may only be removed or reinstalled for repair or replacement. Avoid inserting and removing ChargePod unnecessarily.

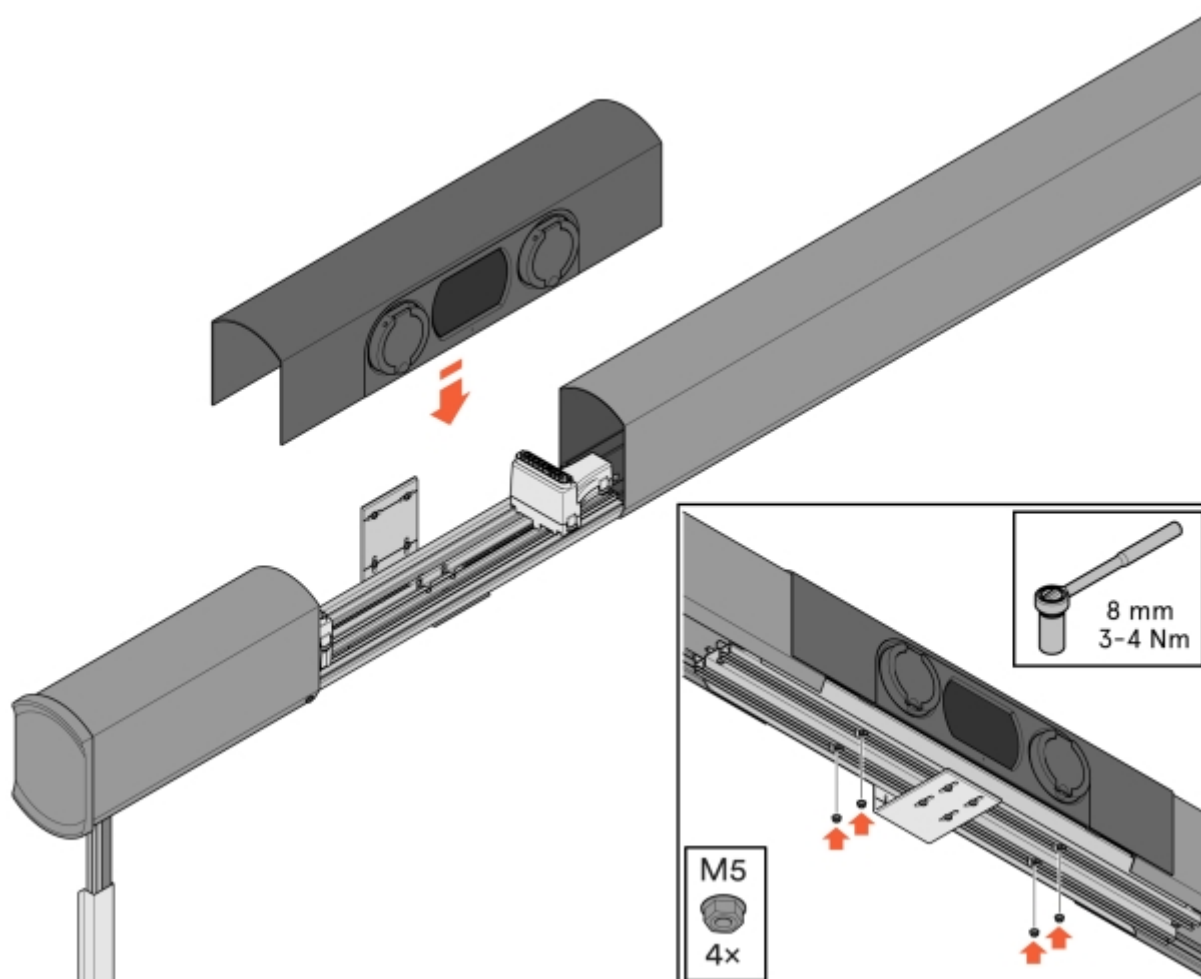

Image 52: ChargePod installation



**Caution!**

Install ChargePod straight down from above, avoiding tilting ChargePod.

## Install GroundConnection

### Cables

To ensure proper functionality and long-term operation, we recommend the following cables:

- **Power cable:** Aceflex 5G16
- **Data cable:** CAT6 UTP/FTP, black
- **Signal and 24 V cable:** Aceflex 5G1.5

**Keep in mind!**

ConnectCable for Amp5 must not be laid in the ground.

- 1 Cut the pipe profile to match the height of the pole, ensuring that at least 100 mm of it is embedded in the ground.
- 2 Use the drilling template to drill two holes in ConnectBar for JunctionBox.

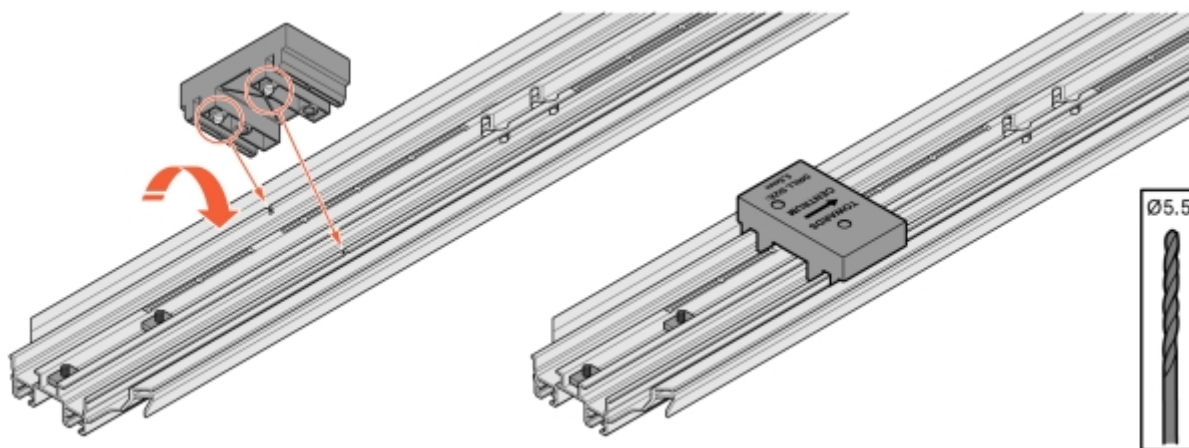

- 3 Check that the pole-mounted cable tray and pipe profile from the ground to the mounting bracket are correctly installed, aligned, and secured.

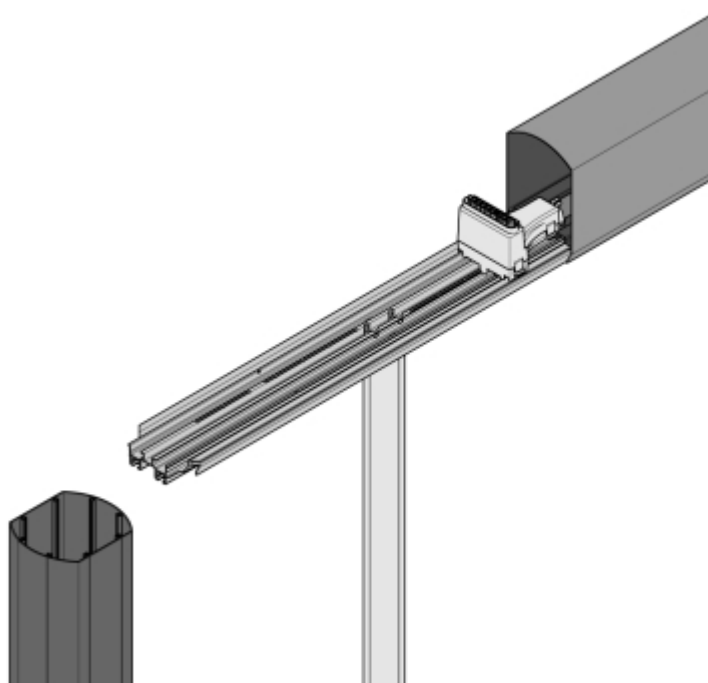

Image 53: Checking positioning and mounting

- 4 Check that the distance between the pole and the pipe is  $585 \pm 20$  mm.

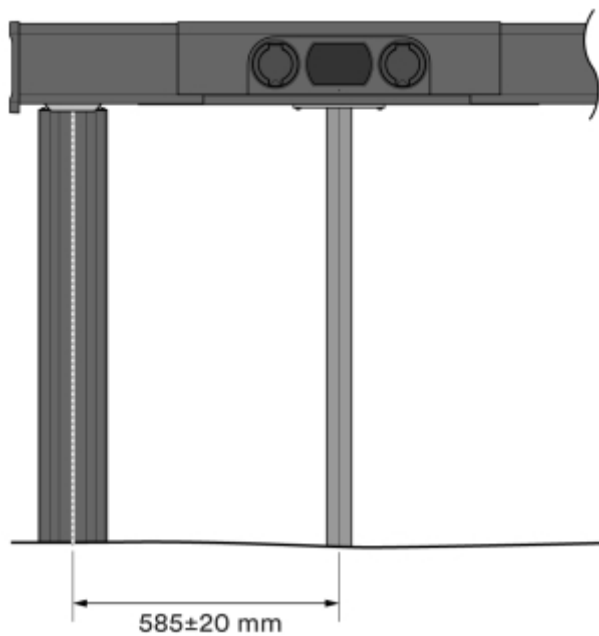

Image 54: Check of distance

- 5 Connect the power and data cables to their other connection points.

6 Run the power cables and data cables through the adapter.

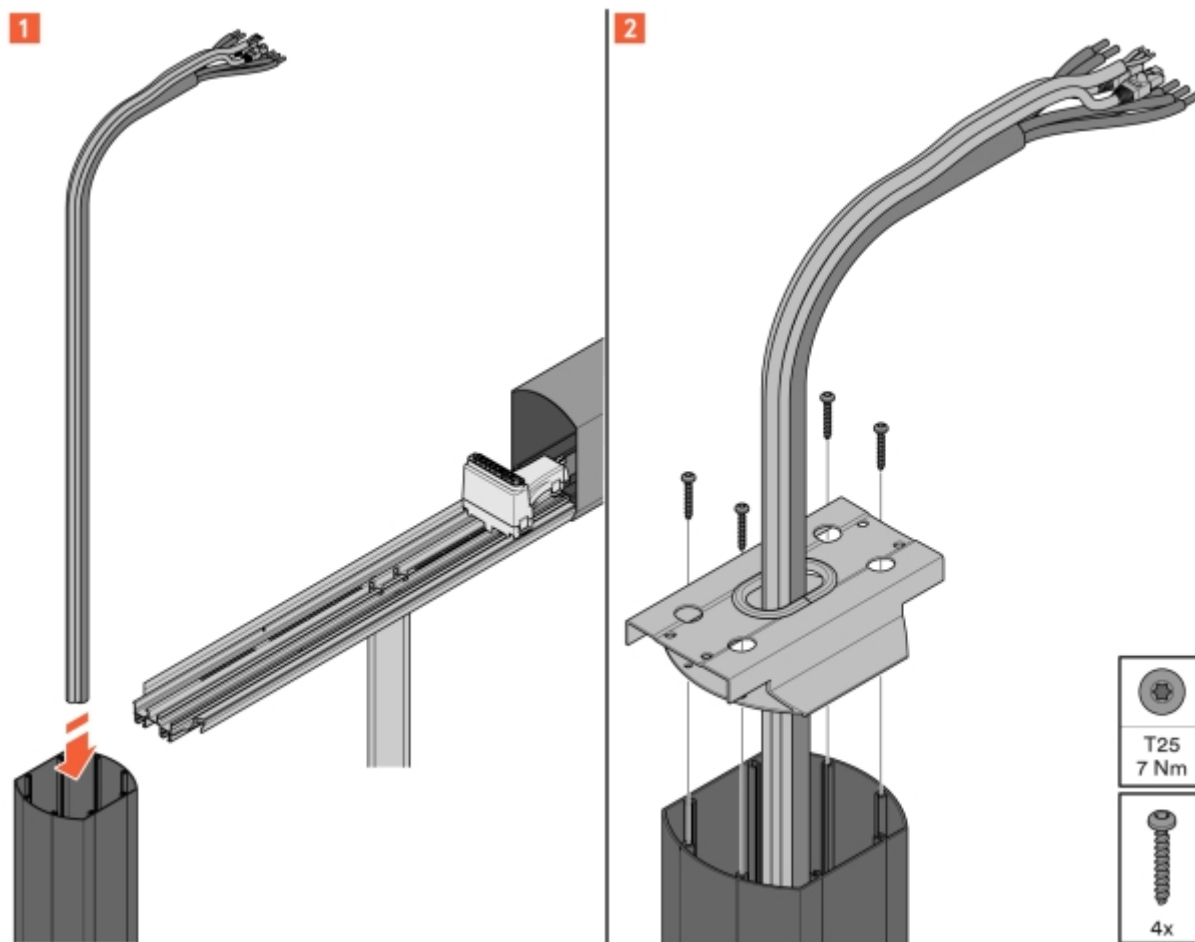

Image 55: Power and data cables

7 Position the adapter on the pipe and secure it with four screws.

8 Remove the cover from JunctionBox.

9 Snap the bottom part onto the mounting bracket.

10 Secure the lower section to the bracket using two screws in the new holes.

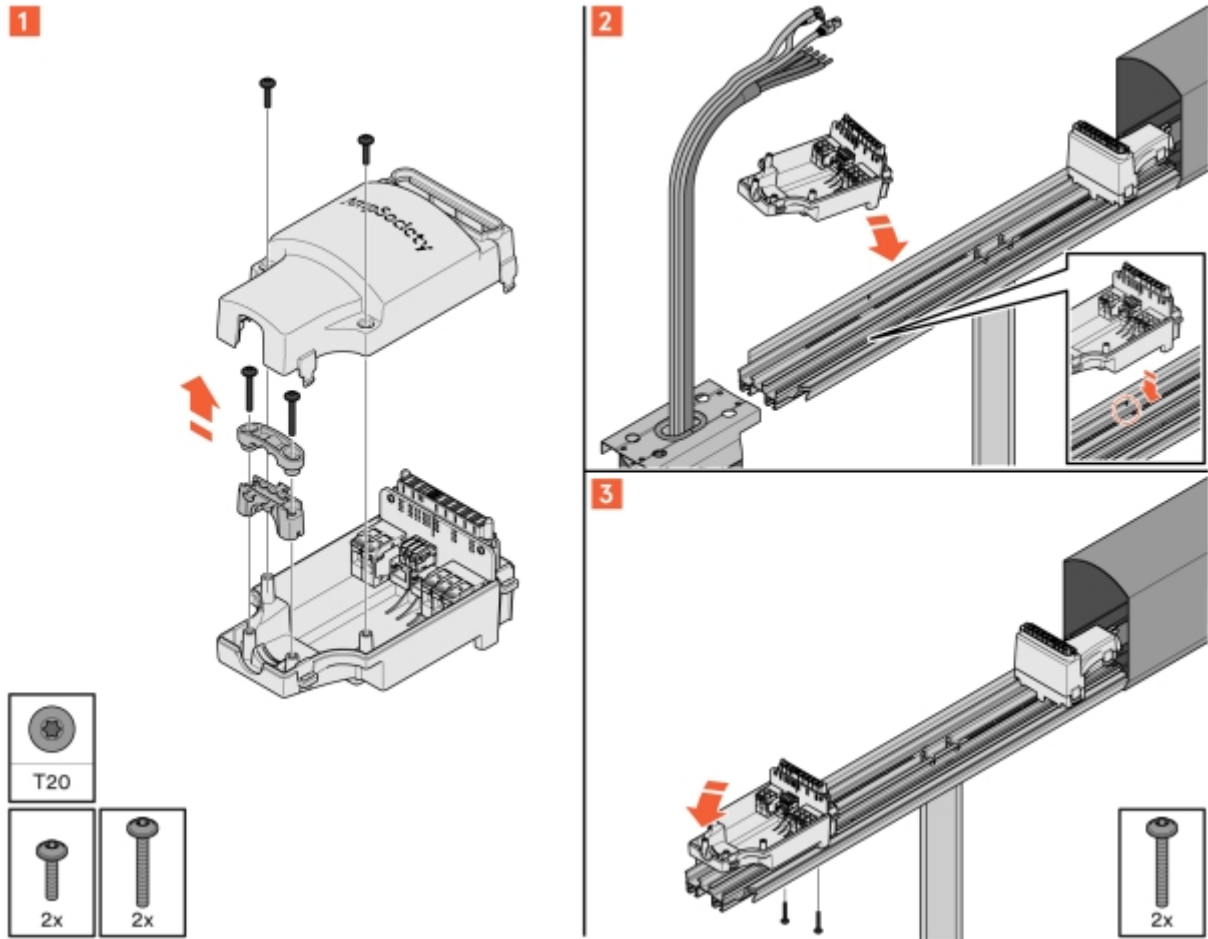

Image 56: JunctionBox installation



**Keep in mind!**

Do not tighten beyond the specified torque to avoid damaging the product.

11 Check all cables before installation.

12 Install the power cable and secure it with the cable clamp.

13 Install the data cables, securing them with three cable ties and the second cable clamp.

14 Fit the cover and secure it with two screws.

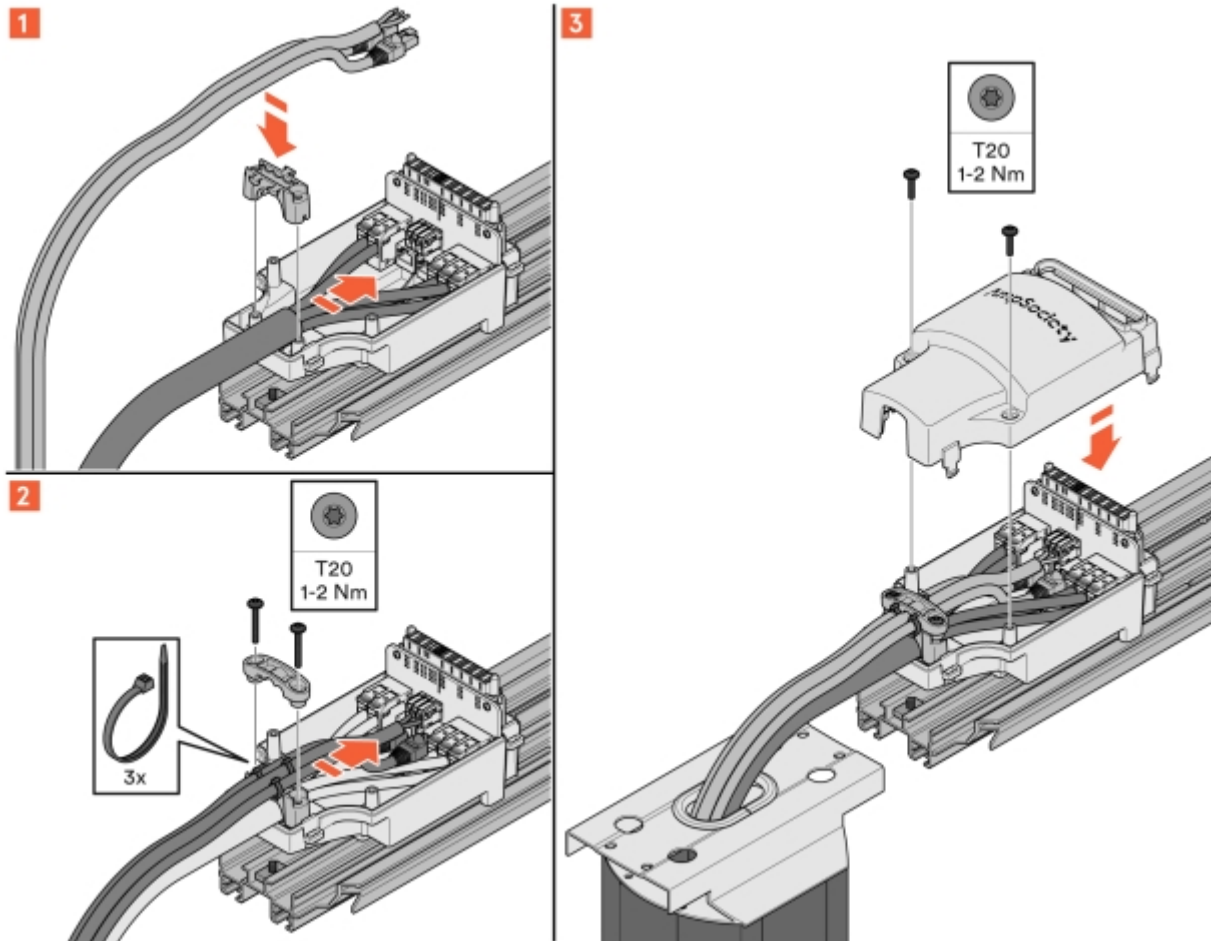

Image 57: Connecting JunctionBox

15 Position CableBar on the mounting bracket and secure it with four screws.



**Keep in mind!**

When installing CableBar, be careful so as not to damage the cables.

16 Secure CableBar to the bracket with two screws.

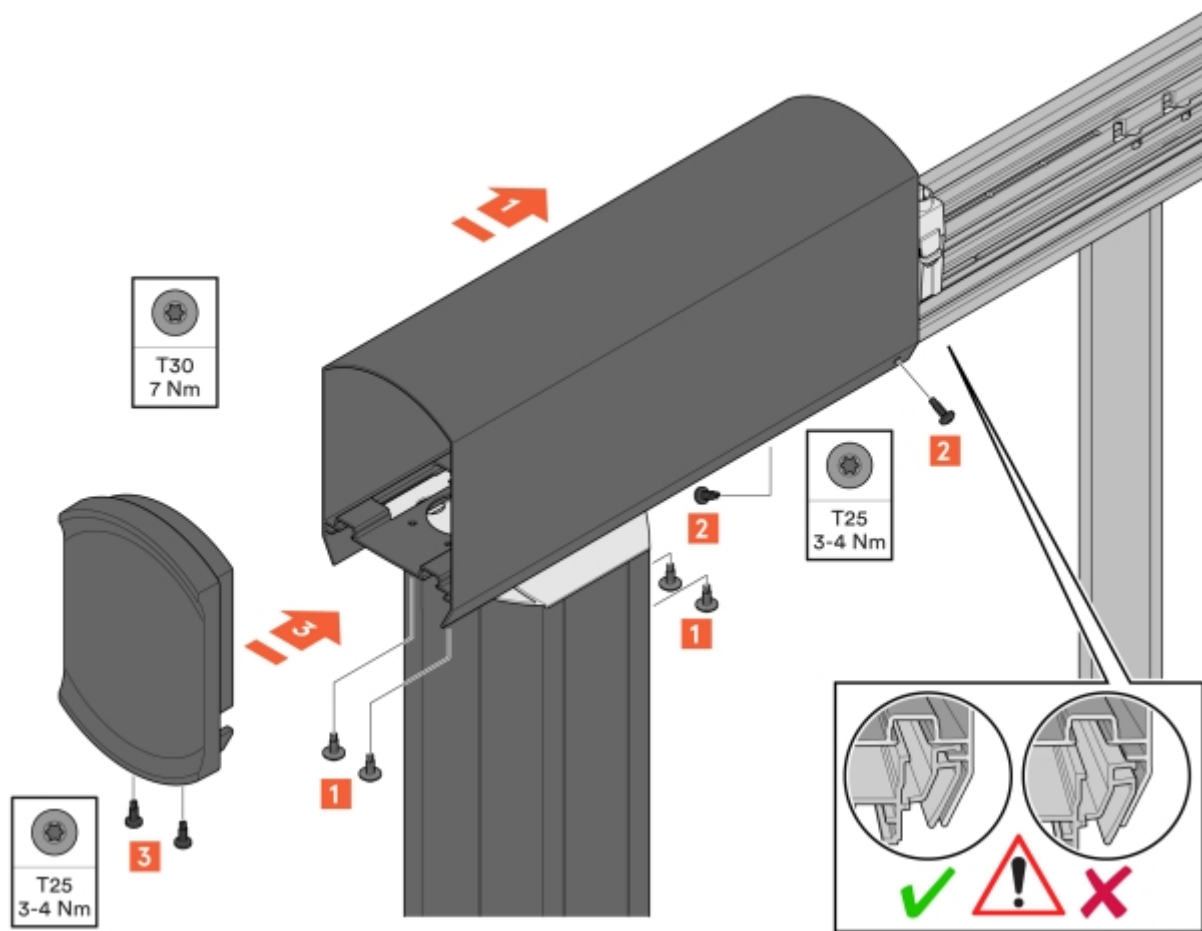
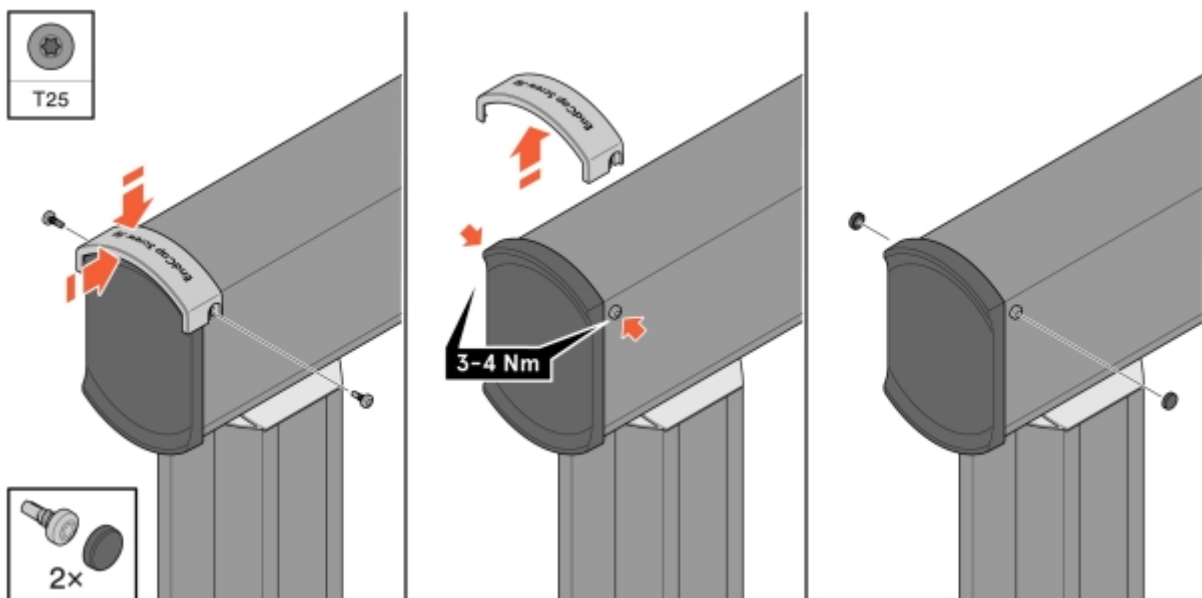

Image 58: CableBar installation

17 Place the drilling template over EndCap and screw the screws in loosely.

18 Remove the drilling template and tighten the screws to the specified torque.



19 Position ChargePod and secure it with four nuts.

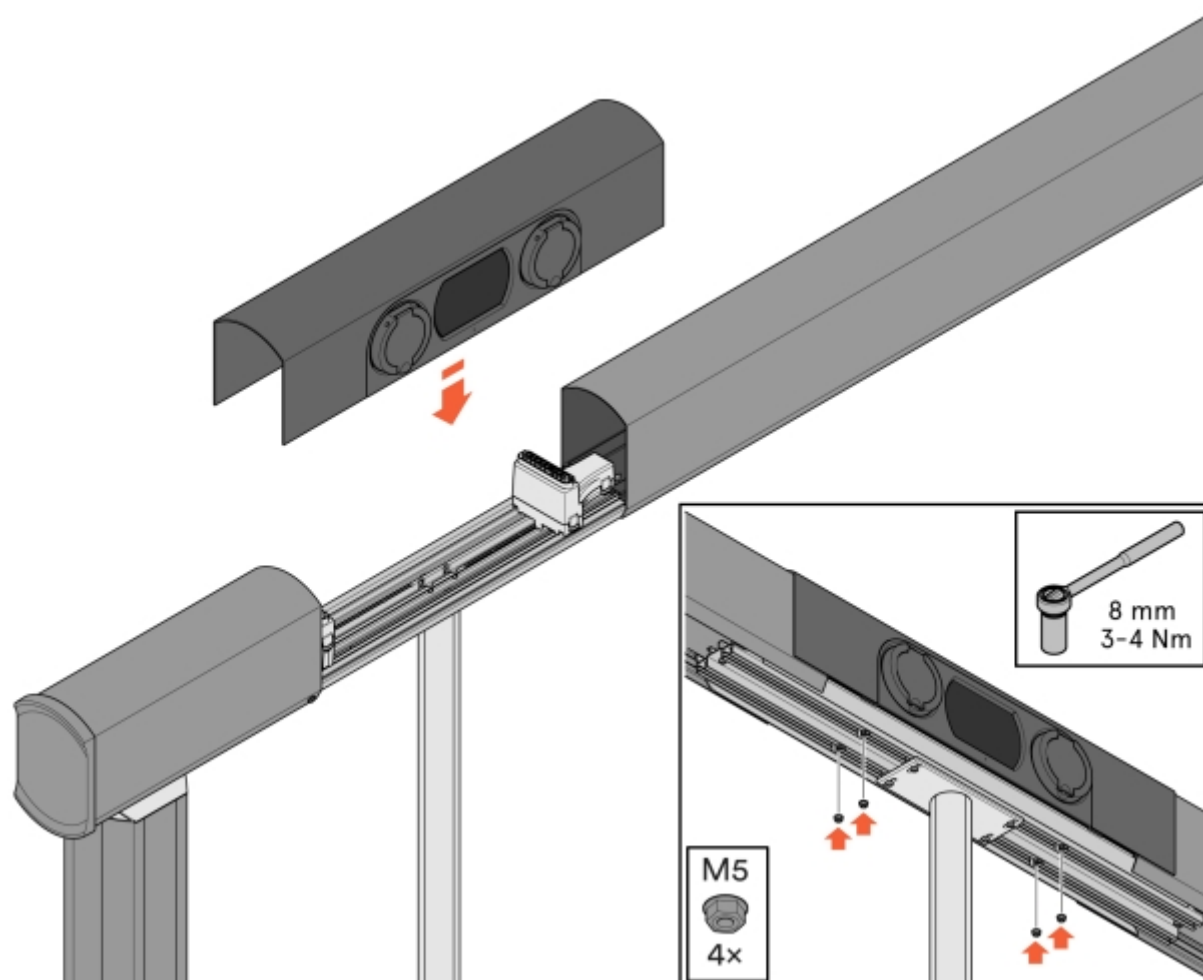

Image 59: ChargePod installation



**Caution!**

Install ChargePod straight down from above, avoiding tilting ChargePod.

## Install ChargeHook

- 1 Slide the profile into the front slot on the bracket until it comes to rest against the sliding nut.
- 2 Fit the sliding nut into the rear slot in the bracket.

3 Tighten the sliding nut.

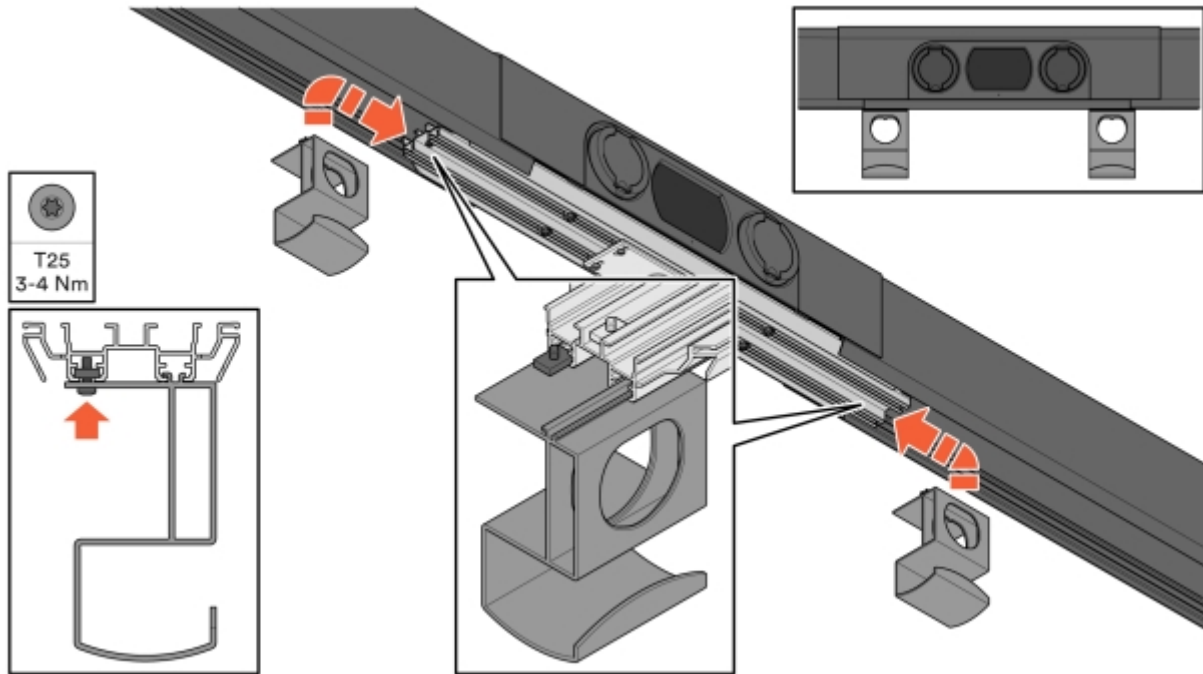

Image 60: ChargeHook installation

# Electrical installation

---

## SmartHub components

### SmartHub – Revision 01 (serial no. 01xxxxxx)

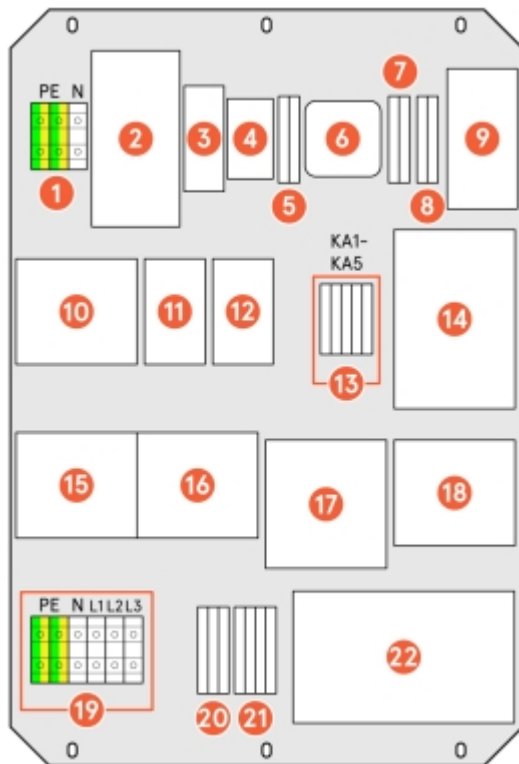

Image 61: SmartHub components – Revision 01

- |    |  |    |   |
|----|--|----|---|
| 1  | Incoming PEN   | 12 | RCBO, power supply to LED   |
| 2  | Main connector, 3p                                       | 13 | KA1-5 (description missing in PowerPoint)                         |
| 3  | Wi-Fi, on/off button                                     | 14 | Power supply 24 V, 240 W  |
| 4  | Internet indicator, blue or white                        | 15 | Surge protection  |
| 5  | Output to 230 V LED (L1, N)                              | 16 | Main circuit breaker and input current                            |
| 6  | Accessory: Light control                                 | 17 | Battery module  |
| 7  | 24 V power supply to ChargePod (24 V, Gnd)               | 18 | Place for router  |
| 8  | Continuity in the pilot control circuit (Pilot1, Pilot2) | 19 | Terminal block for outgoing cables (for SmartHub StandAlone only) |
| 9  | Network switch for ChargePod                             | 20 | Load balancing input RS-485                                       |
| 10 | MCB, power supply current bar                            | 21 | Fire alarm input (24 V, Gnd, Alarm-, Alarm+)                      |
| 11 | MCB, control voltage 230 V                               | 22 | Central computer  |

**SmartHub – Revision 00 (serial no. 00xxxxxx)**

Image 62: SmartHub components – Revision 00

- |   |                                     |    |                            |
|---|-------------------------------------|----|----------------------------|
| 1 | Main contactor, output power        | 10 | Auxiliary contactors       |
| 2 | Wi-Fi button                        | 11 | Power supply unit for 24 V |
| 3 | Internet indicator                  | 12 | Terminal block             |
| 4 | 24 V disconnection/pilot connection | 13 | Surge protection           |
| 5 | Plejd for LED strip                 | 14 | UPS                        |
| 6 | Switch for ChargePod communication  | 15 | Place for router           |
| 7 | Main fuse                           | 16 | Incoming PEN               |
| 8 | Fuse for 24 V (auxiliary)           | 17 | Central computer           |
| 9 | Fuse for LED strip                  |    |                            |

## Connect SmartHub

- 1 Install screw connection for main cable (max. 35 mm<sup>2</sup>, 100 A).
- 2 Connect the N-L1-L2-L3 wires to QD1 on the main switch.
- 3 Connect the ground wire (PE) to the ground terminal.
- 4 Tighten all screw connections on SmartHub before commissioning.

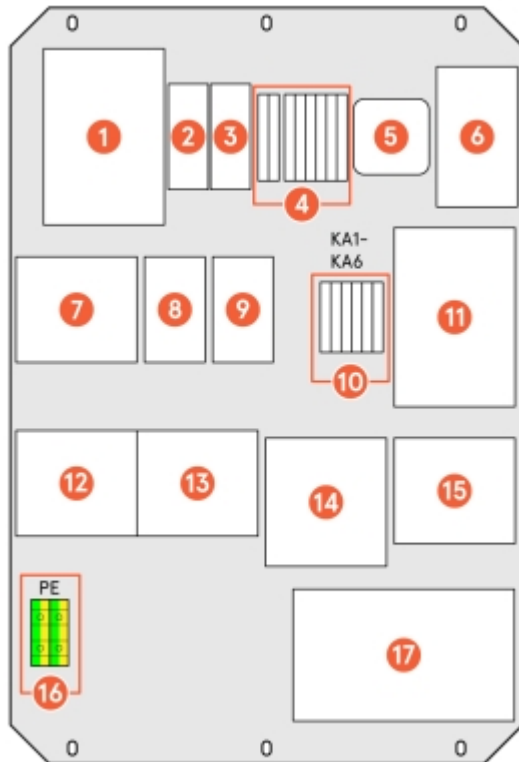
## Connect the network from ChargePod to SmartHub

### 1 Scenario 1: SmartHub with one ConnectCable



Image 63: Connection between SmartHub and one ConnectCable

### 2 Scenario 2: SmartHub with 2x ConnectCable



Image 64: Connection between SmartHub and 2x ConnectCable

### 3 Scenario 3: SmartHub with one WallConnection or one GroundConnection

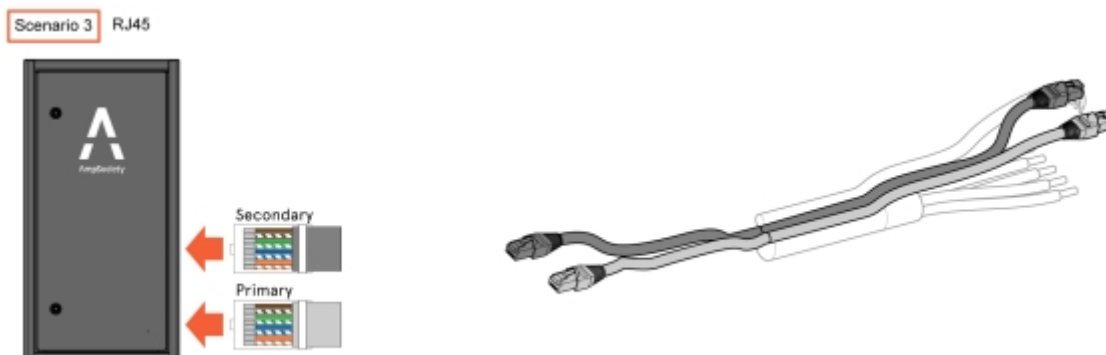

Image 65: Connection between SmartHub and one WallConnection or one GroundConnection

## 4 Scenario 4: SmartHub with 2x WallConnection or 2x GroundConnection

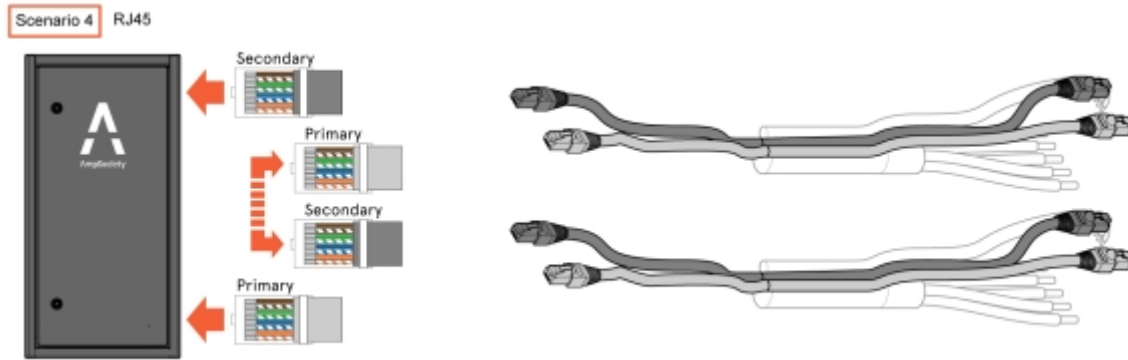

Image 66: Connection between SmartHub and 2x WallConnection or 2x GroundConnection

## Connect Router AmpSociety (part no. 5000207, option for Amp5)

- 1 Install the router using the supplied DIN bracket in position 18 in the SmartHub.
- 2 Connect the prepared 4-pin power cable.
- 3 Connect the two prepared 4G antenna cables to the router. If necessary, move one of the antenna cables from the Amp5 Central Computer to the router.



### Keep in mind!

Make that the cable labelled "5G/LTE" is connected to the "Main antenna mobile" port on the router.

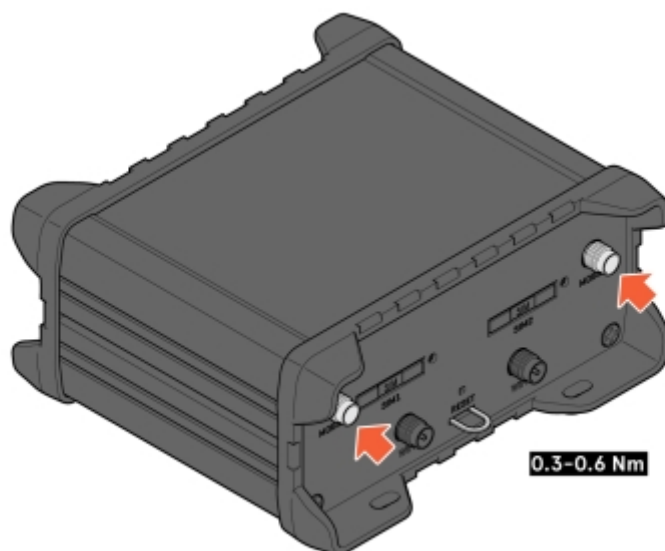

- 4 Connect the prepared network cable from the Amp5 Central Computer to the LAN port on the router.

- 5 If a wired network is to be used, connect it to the port labelled WAN on the router.

## Connect external stop

- 1 Connect cable (E-Stop/fire alarm) to terminal block 404, 405, 406 and 407.



**Keep in mind!**

See connection instructions in the central drawing.

## Lighting connection (optional)

- 1 Install the lighting relay, Plejd controller or similar in SmartHub and connect according to its single-line diagram. Drawing included with SmartHub.
- 2 Configure according to the client's wishes.
- 3 If no other programming information is given, select the Astro function.
- 4 Attach the Plejd sticker or equivalent sticker with code to the inside of the door on SmartHub.
- 5 Connect the lighting to the prepared terminal block.

# Commissioning

## Start-up

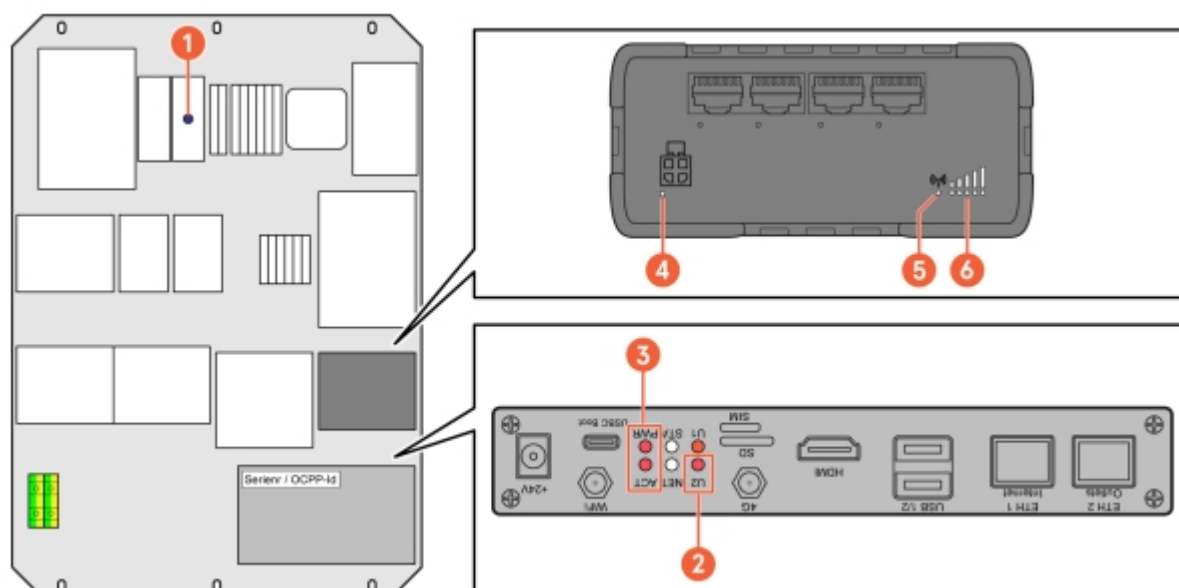

Image 67: SmartHub components

- |   |   |   |                                |
|---|---|---|--------------------------------|
| 1 | Internet indicator                              | 4 | Power (PWR)                    |
| 2 | Wi-Fi status                                    | 5 | 4G connection status indicator |
| 3 | Central computer and software running indicator | 6 | 4G signal strength indicator   |

Start by checking the following lights:

- White lamp for internet (skip if CPO is not being selected)
- LED indicator for central computer
- U1: Software indicator (should flash 0.5 s on, 1.5 s off)
- U2: Wi-Fi indicator
- LED indicators on Teltonika 901 for power, connection status and signal strength. See the details in the following sections.

### Teltonika 901 connection status

Colour and light indications are as follows:

Green and red lights that flash alternately every 500 ms.	No SIM card or incorrect PIN
Green, red and orange lights that flash alternately every 500 ms.	Connecting to GSM
A red light that flashes every second	Connected to 2G, no data session established
An orange light that flashes every second	Connected to 3G, no data session established
A green light that flashes every second	Connected to 4G, no data session established
A red light that remains lit but flashes rapidly when data is being transferred	Connected to 2G with established data session

An orange light that remains lit but flashes rapidly when data is being transferred      Connected to 3G with established data session

A green light that remains lit but flashes rapidly when data is being transferred      Connected to 4G with established data session

## Signal strength

Each lit LED indicates the router's signal strength as follows:

0	≤ -111 dBm
1	-110 to -97 dBm
2	-96 to -82 dBm
3	-81 to -67 dBm
4	-66 to -52 dBm
5	≥ -51 dBm



### Keep in mind!

At least four LED indicators for signal strength are required.

## Connect to SmartHub via Wi-Fi (primary) or Ethernet (backup)

1 Connect to SmartHub via Wi-Fi:

1.1 If Wi-Fi is not enabled, enable Wi-Fi by pressing the Wi-Fi button in SmartHub; see **Image 61**.



### Keep in mind!

When Wi-Fi is enabled, two QR codes appear alternately on the screen – one labelled SSID (for connecting to Wi-Fi) and one labelled Hub Config (for managing settings).

1.2 Check the Wi-Fi status via the LED indicator (as illustrated above).



### Keep in mind!

Wi-Fi deactivates automatically after 60 minutes.

1.3 Connect to the Wi-Fi hotspot with your computer or phone using one of the following options:

- Scan the QR code labelled SSID on the screen in ChargePod.
- Search for wireless networks on your device.

SSID: SERIAL NO (the serial number of SmartHub can be found on the central computer; see **Image 61**.)

Password: "privet-morgen-helot-heap-axon"

## 2 Connect to SmartHub via Ethernet:



### Keep in mind!

This is an alternative method that can be used if it is not possible to connect to a Wi-Fi hotspot.

### 2.1 Connect an Ethernet cable or USB-to-Ethernet adapter to the LAN port of the Teltonika router.

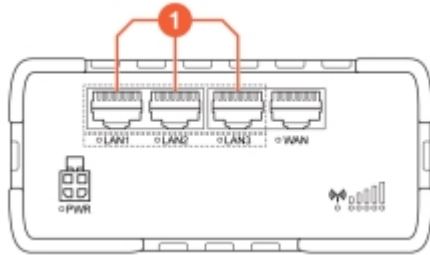

Image 68: Teltonika router

### 1 LAN ports



### Keep in mind!

The Ethernet cable must only be connected in Teltonika. The network switch at position 06 is only for ChargePod communication.

## Managing settings in the web interface

### 1 There are two ways to access the settings:

- Scan the QR code labelled **Hub Config** that is displayed on the screen.
- Manually go to one of the following URLs:
  - o <http://192.168.4.1>
  - o <http://serien/>



### Keep in mind!

When reception is poor, some phones use their own 4G connection instead of Wi-Fi, which means you cannot access the central computer via Wi-Fi. Turn off mobile data on your phone to avoid this problem.

### 2 Log in.

- 3 Select one of the following options for the setup process:
- **Guided setup:** Guided and automatic configuration of all settings
  - **Manual setup:** Manual configuration of all settings

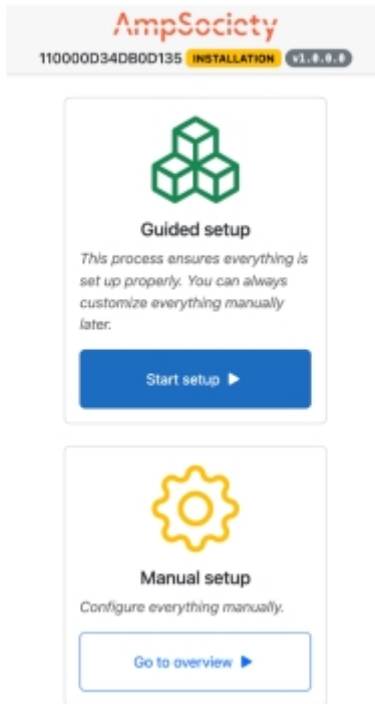

Image 69: Start page

4 For **Guided setup**:

- 4.1** Select **Start setup**.
- 4.2** In the step for **Connectors**, check that there are as many rows for serial numbers under **Module** as there are ChargePods (see Section 7.1 "What is ConnectorID?", **page 64** for more information).  
Select **Next** to confirm and go to the next step.
- 4.3** In the step for **OCPP**, enter the OCPP server URL manually if you want to connect to another operator and select **Next**.
- 4.4** In the step for **Complete**, check the settings and select **Finish** to confirm.

## 5 For **Manual setup**:

### 5.1 Select **Go to overview**.

### 5.2 Assign ConnectorIDs:

(see Section 7.1 "What is ConnectorID?", **page 64** for more information)

- From **Overview** in the top left menu, select **Map Connectors on the Service page**.
- Select **Auto-number connector IDs**.  
Smarthub now assigns ChargePod ConnectorIDs.
- Select **Save changes** to save the assignment.
- Disable **Service mode** to exit.

### 5.3 Make settings for OCPP:

- Go to **Settings** in the left menu.
- Enter the OCPP address in the **Server URL** field.
- The OCPP identity is 12 characters as standard and is already entered under Settings and is marked on the front of the central computer.
- Go to **Overview** in the left-hand menu and make you have an internet connection and contact with your operator's OCPP server.

## What is ConnectorID?

### INFO

ConnectorID is a sequential number series starting from 1 per Smarthub. The order of the ConnectorID has no physical meaning for the function. The ConnectorID is then linked to the socket number.

## Electrical testing

### Insulation testing

Use max. 370 V. On most measuring instruments, this is insulation testing 250 V (not 500 V or 1 kV).

To perform insulation testing via ConnectBar, the measurement must be taken on the top of the main contactor.

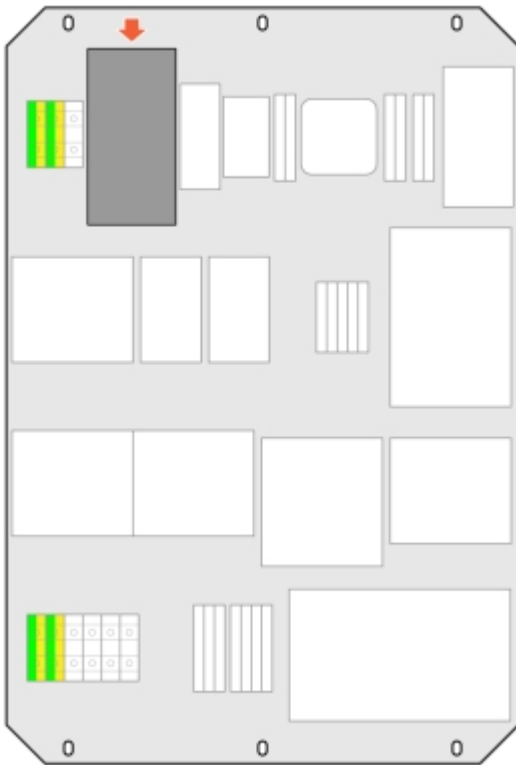

Image 70: Main contactor

**Keep in mind!**

Insulation testing at 500–1000 V does not damage the components, but may cause the surge protector to connect the voltage to ground (0 MΩ).

## Z-line test

- Fuse type: NV (blade fuse)
- Fuse I: 35 A (overload protection, nominal load 32 A)
- Fuse t: 1 s (tripping time)
- Isc factor: 0.66

## RCD test

Perform an RCD (Residual Current Device) test on each socket with an auto sequence for type B residual current circuit breakers.

- 1 Put SmartHub into service mode.
- 2 Connect the EVSE adapter to the socket.
- 3 Set the socket to position C.

- 4 Start the auto sequence on the test instrument for type B residual current circuit breakers.
- 5 Check that the residual current circuit breaker trips – this can be seen on the instrument display.
- 6 Reset the switch by moving it to position A and then back to position C in quick succession.
- 7 Repeat steps 4–6 until the auto sequence is complete.
- 8 Repeat the entire test for all sockets.

# Care

---

## Cleaning the charging system

Use a damp cloth to clean the charging system components (ConnectBar, SmartHub, displays).

## Visual inspection

- Make sure that the entire power bar system is securely fastened and that no part of the power bar is loose.
- Check the Type 2 connector on ChargePod to ensure there is no damage to the contact surfaces.
- Make sure that the cover on the Type 2 connector closes properly using the spring mechanism.

## Check the residual current circuit breaker

- 1 Start charging with EVSE adapter or car.
- 2 Hold a magnet close to the T mark below the display.

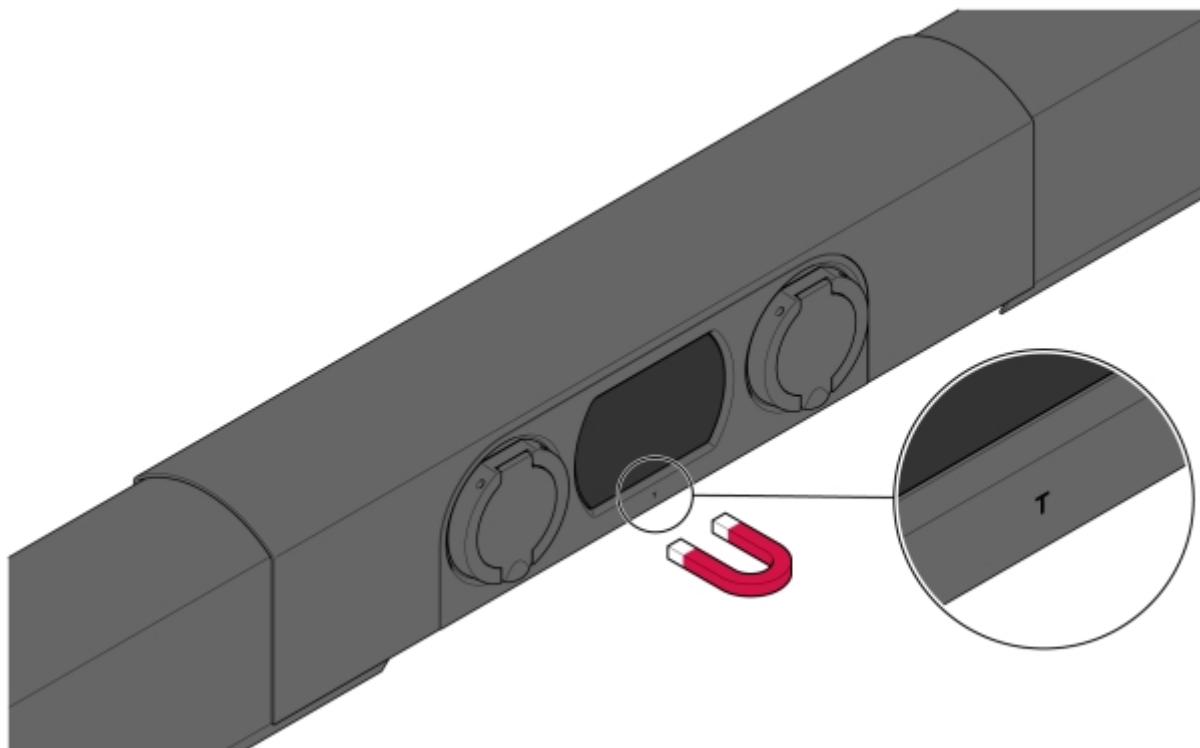

- 3 When the power is interrupted, a ground fault should appear on the display.

- 4 Remove the EVSE adapter or charging cable from the socket to reset the residual current circuit breaker.
- 5 Repeat steps 1–4 for each ChargePod.

## End use

---

### LED indicators

The LED at the top left of the display provides information about the current flow:

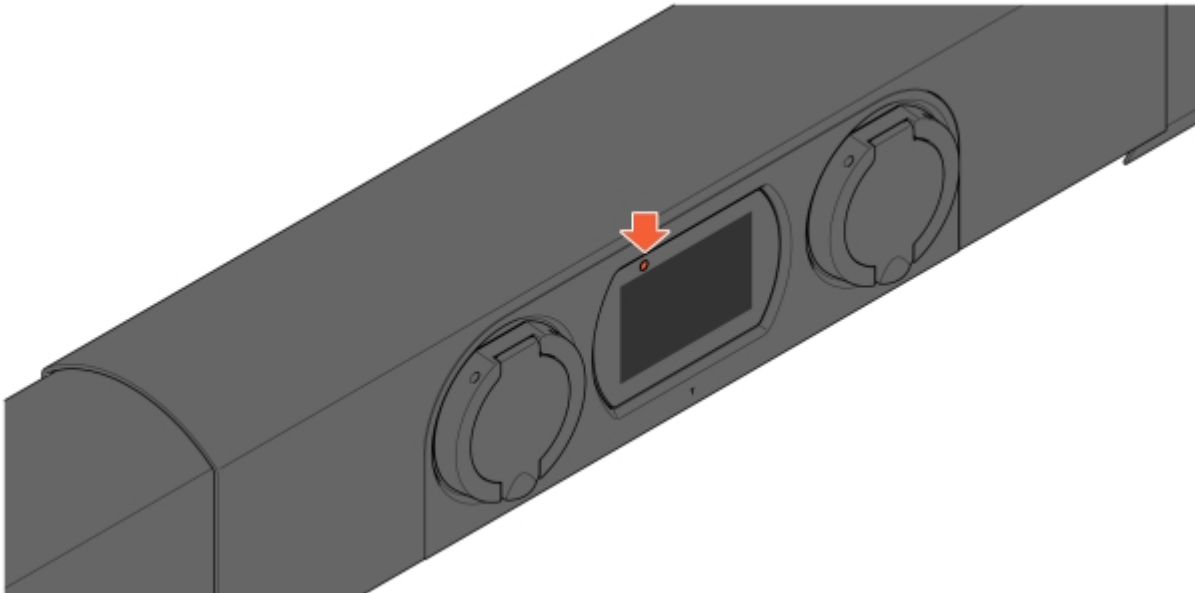

Image 71: Location of the LED

- Red flashing light: the left socket is supplying power.
- Green flashing light: the right socket is supplying power.



#### **Keep in mind!**

The LED indicator is set to 1,000 pulses per kWh.

### Thermal limitation

Amp5 is equipped with a thermal limiting algorithm that can limit charging at high ambient temperatures:

- The algorithm is only activated at temperatures above 20°C.
- At temperatures below 20°C, charging is not affected.
- At temperatures above 20°C, some charging sessions may be restricted from using the full 32 A.
- The limit is controlled by temperature sensors inside the product. Ambient temperature and ventilation may affect performance.

### RFID reader

The RFID reader above the centre of the display is used to start charging:

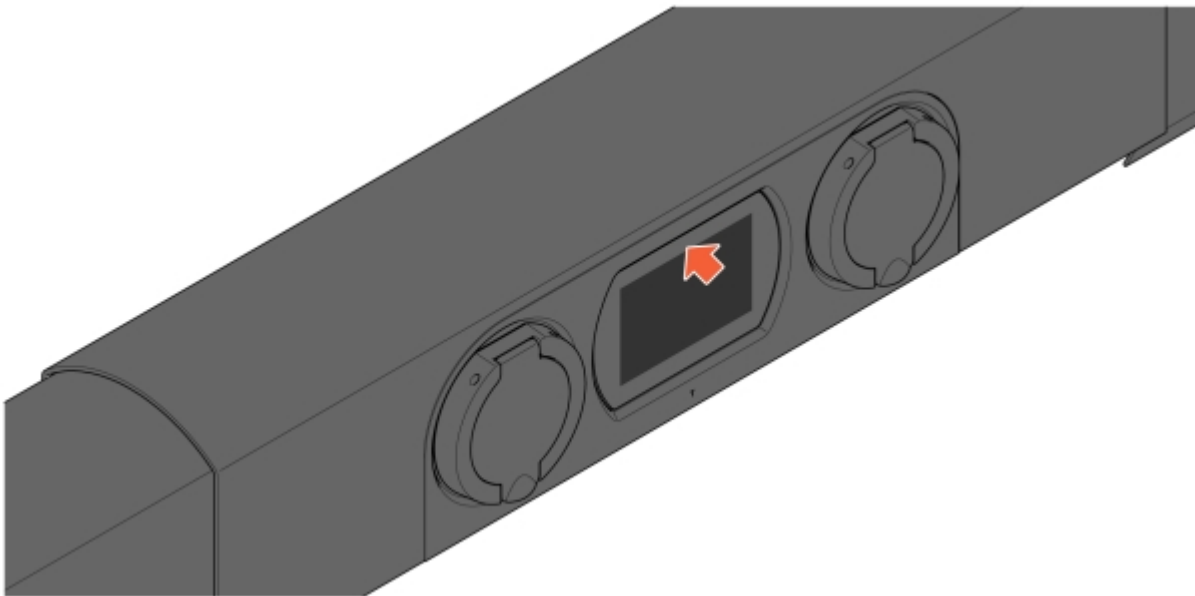

Image 72: Location of RFID reader

Both sockets on ChargePod share an RFID reader. The cable that was last connected to ChargePod is the one that will be activated when an authenticated RFID tag is read.

## Display components

The display shows the following information:

1. **Help text:**
  - Description of how to start charging.
  - Symbol for an RFID tag.
2. **Green circles:**
  - Either the station's ConnectorID (prefixed with #, e.g. #10)
  - Or any parking number or name assigned by the operator (e.g. 3, ABC123).

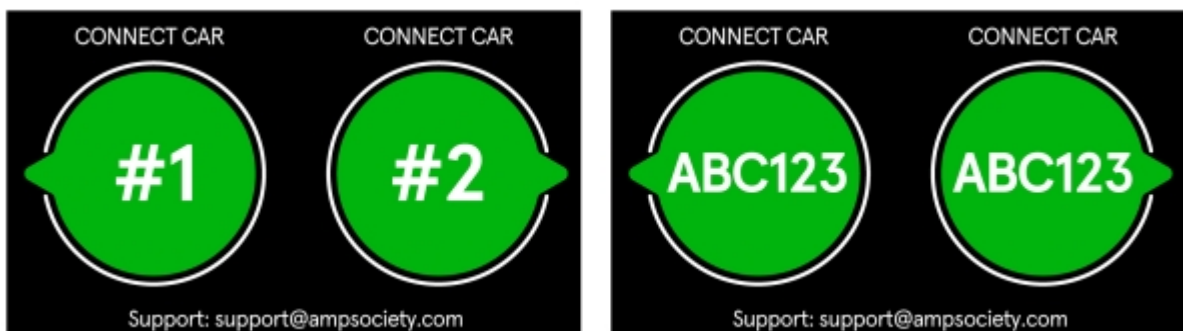

Image 73: Examples of ConnectorIDs and parking numbers

3. **Error messages:**
  - Error code for charging system fault.  
Please quote this error code when contacting the operator.

**4. Optional text:**

- Optional information that the operator may enter.

# Troubleshooting

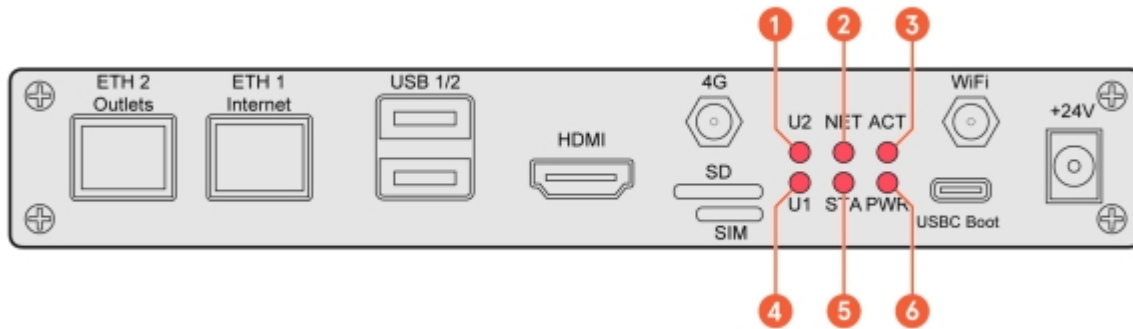

Image 74: Status LEDs

- |   |   |   |   |
|---|---|---|---|
| 1 | U2 (User2, lights up when Wi-Fi for service mode is activated)          | 4 | U1 (User1, Heartbeat Agent)                             |
| 2 | <b>Not used:</b> NET (GSM module, indicates red when there is coverage) | 5 | <b>Not used:</b> STA (Supply voltage to the GSM module) |
| 3 | ACT (RaPi4 eMMC access LED)   | 6 | PWR (RaPi4 POWER LED)                                   |

## Error codes

### Error codes

The error codes below are sent to the charging station operator as VendorErrorCode. Several of these are also shown to the end user on the display.

No	Name	Description	Action	Note
0	None	No error		
1	NetworkConfigurationError			
2	ComponentError			
8	EnergyMeterCommunicationError			
15	FuseEnergyMeterCommunicationError	The load balancing electricity meter is not communicating	If BUS loop (RS485) is used, check the connections, especially A/B	If it is not visible, it is offline
16	LowVoltage	Low voltage in ChargePod	Measure incoming voltage to SmartHub, measure voltage in outlets	Charging is disabled due to low voltage, missing phase, poor contact in the connections, or a faulty relay in ChargePod
18	DiodeError	Communication error between car and socket	Make sure that GND on the 24 V loop is in contact with true ground	Ground fault in CP communication to the car

No	Name	Description	Action	Note
19	InvalidPp	Cable fault on the charging cable		Fault in customer's charging cable
20	InvalidCp	Signal communication between car and socket not working properly	Measure the rise time of the CP signal with an oscilloscope	The rise time on the curve must be within the standard values; some cars have a lower tolerance level than others.
21	LockMissing	No motor lock communication	Replace ChargePod with a new one	It is not possible to see the lock moving when attempting to operate it
22	StationOffline	One or more charging centres are offline within the same station (same network)	Check the internet connection and try connecting to the router	
23	StationUnresponsive	Something is wrong with the charging station	Contact Technical Support	
25	FirmwareUpdateInProgress	Updates are performed by the central computer or NodeBoard	Wait until the update is complete	
26	FirmwareUpdateFailure			
30	EVCommunicationError			
31	Other			
32	RCD fault	The residual current circuit breaker (ground fault detection) has tripped	Disconnect all charging cables from ChargePod to reset the ground fault circuit	No voltage in the socket
33	MainFusePhaseLowVoltage			
35	FuseTripped	35 A fuse in ChargePod has tripped	Disconnect all charging cables from ChargePod to reset the fuse circuit	More power has been drawn, either briefly (short circuit) or for a long period (overload)
36	DisobedientLoad	Car has consumed more power than permitted	Contact Technical Support	
37	SafetyRelayError			
38	ChargingRelayError			
95	BarContinuity			
99	EmergencyStop			

## Load balancing

---

### Carlo Gavazzi EM530

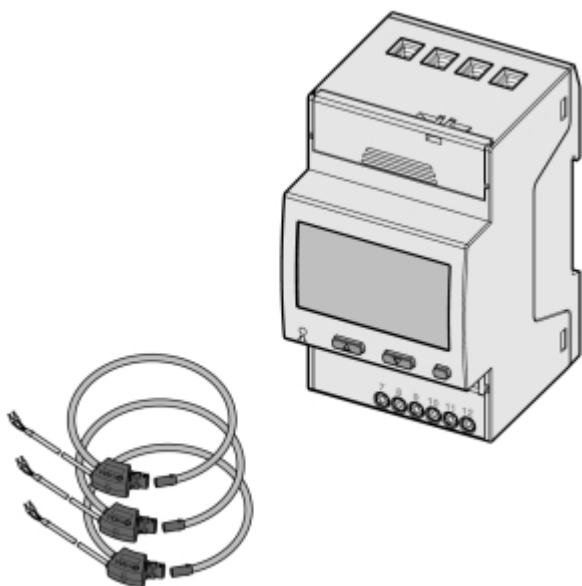

Image 75: Energy meter and current transformers for Carlo Gavazzi EM530

Product type	Model	Details
Energy meter	EM530DINRG53XS1X	
Current transformer	ROG 0.33 V	Available in various diameters, all sizes can handle 20–4000 A



#### Keep in mind!

Be sure to install the current transformers so that the current is measured in the correct direction, marked with an arrow.

## Connect the EM530 energy meter

- Inputs 13–18 on the energy meter are used for connecting current transformers.

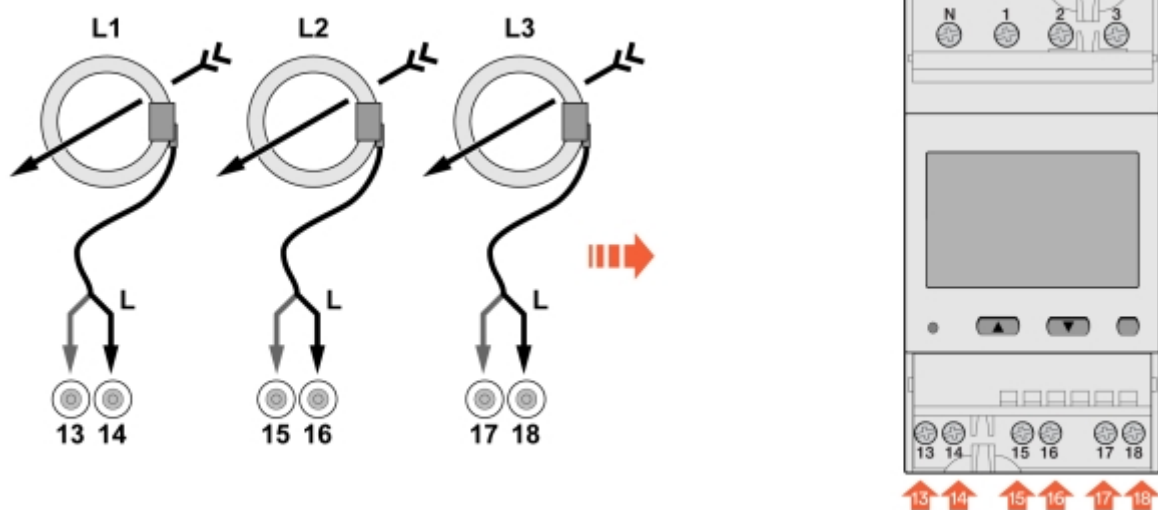

Image 76: Inputs 13–18 on the energy meter

- Inputs N and 1–3 on the energy meter are used for connecting supply voltage (3-phase 230 V).

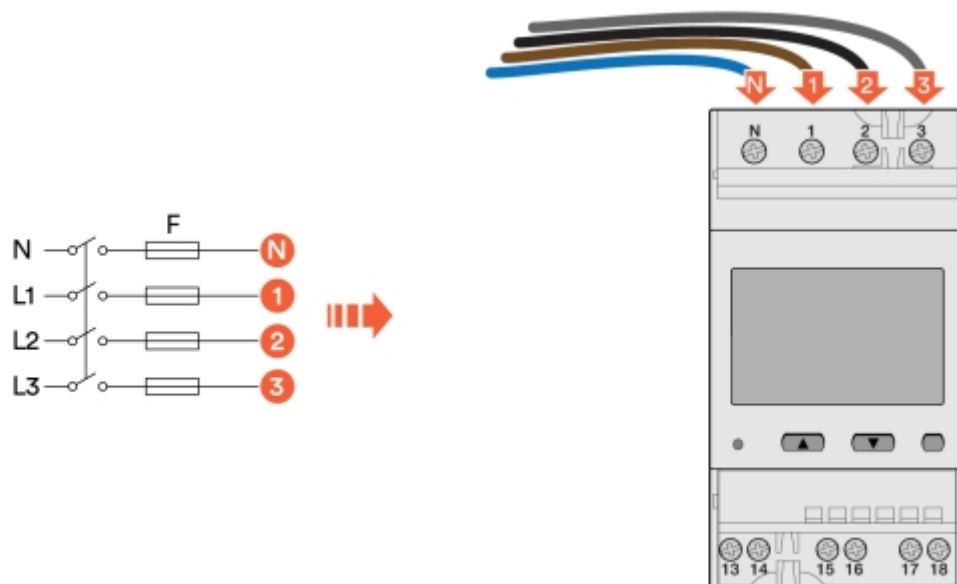

Image 77: Inputs N and 1–3 on the energy meter



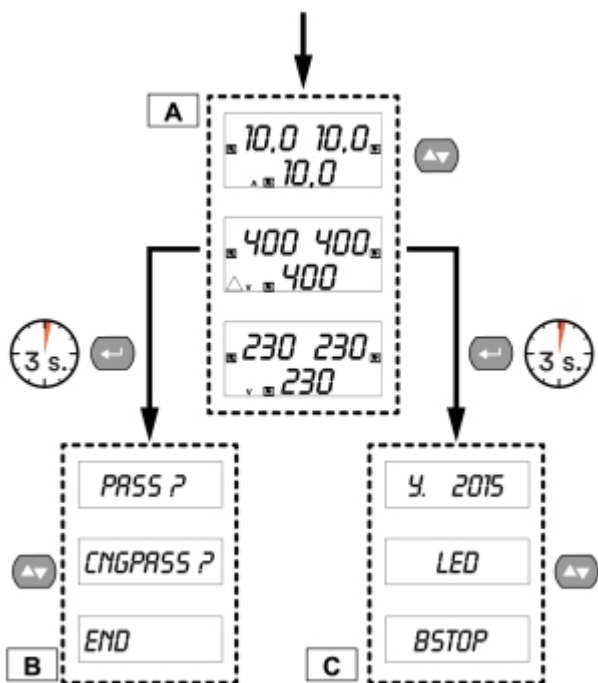

Image 79: Navigation in EM530

## Menu selection EM530

Below are some menu options that are relevant for the installation of dynamic load balancing with the EM530 energy meter.



**Keep in mind!**

For complete information about the energy meter and its menu, see the product's own manual.

Menu selection	Explanation	Use value
PASS	Enter password	0
Add	Series address	X*
SEnSO	Select which current sensor is used	roG
Ct Prin	Nominal primary current of the current sensor	1.00k

\*The energy meters have unique serial addresses. Program and enter the selected address in the web interface under **Fuses**.

## Carlo Gavazzi EM210

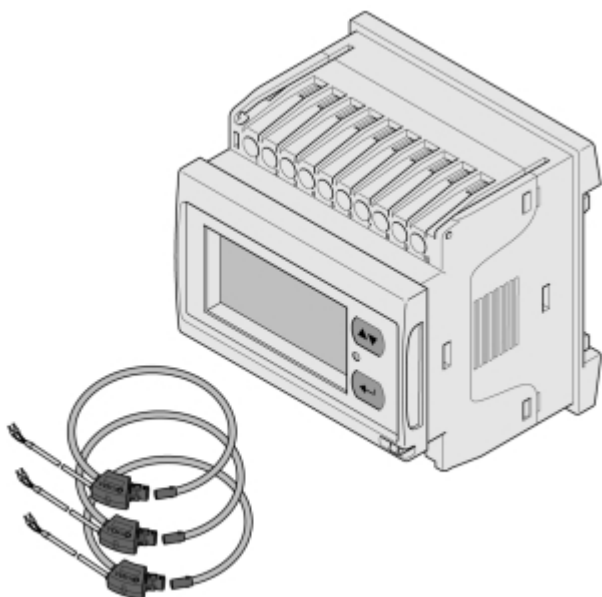

Image 80: Energy meter and current transformers for Carlo Gavazzi EM210

Product type	Model	Details
Energy meter	CarloGavazzi EM210 (MV5), EM21072DMV53XOSX	E number: 0921001
Current transformer	ROG 0.33 V	Available in various diameters, all sizes can handle 20–4000 A



### Keep in mind!

Be sure to install the current transformers so that the current is measured in the correct direction, marked with an arrow.

## Connect the EM210 energy meter

1 Inputs 1–6 on the energy meter are used for connecting current transformers.

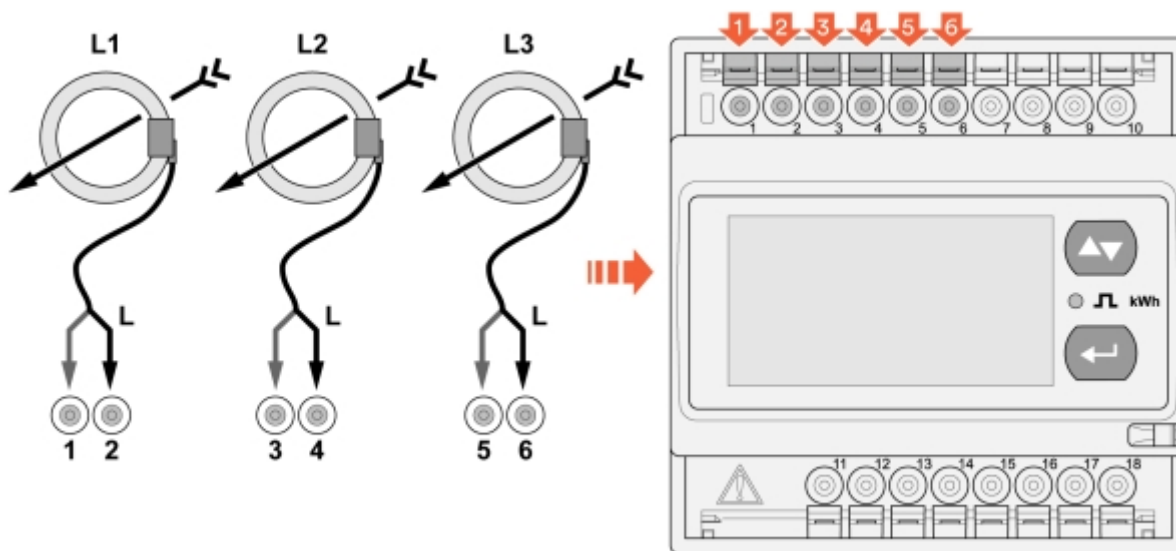

Image 81: Inputs 1–6 on the energy meter

2 Inputs 7–10 on the energy meter are used for connecting supply voltage (3-phase 230 V).

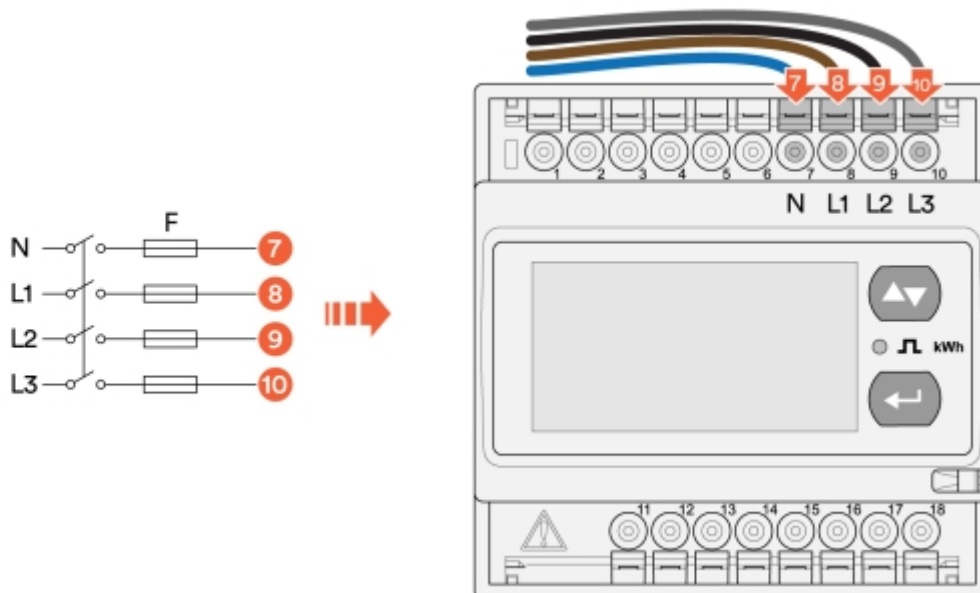

Image 82: Inputs 7–10 on the energy meter

3 Inputs 15–18 on the energy meter are used for connection with RS485 (BUS).

- B- on input 16 with input 18.

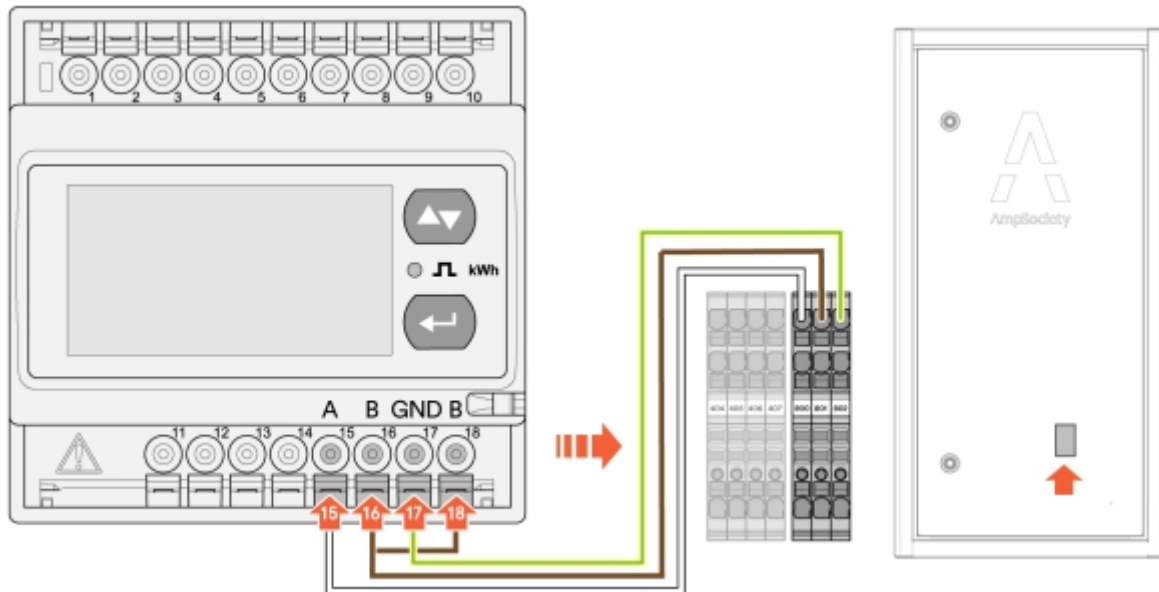





Image 83: Inputs 15–18 on the energy meter

## Configure EM210

- 1 Energise EM210.
- 2 Press and hold  for more than 3 seconds.
- 3 Enter password: 0
  - If necessary, use  to enter the password.
- 4 Press and hold  for more than 3 seconds.
- 5 Scroll with  to find the right setting.

### Programming example for Carlo Gavazzi EM210

For other product solutions, please contact AmpSociety (Section 1.4 "Installation support", page 6).

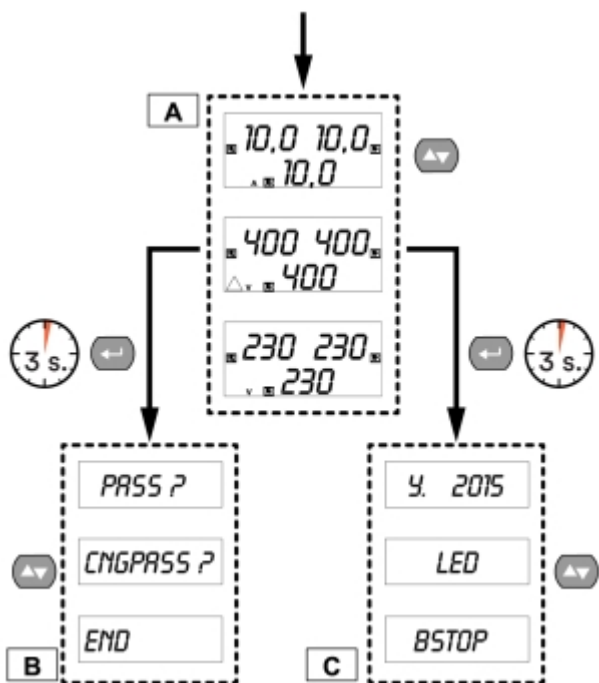

Image 84: Navigation in EM210

## Menu selection EM210

Below are some menu options that are relevant for the installation of dynamic load balancing with the EM210 energy meter.



**Keep in mind!**

For complete information about the energy meter and its menu, see the product's own manual.

Menu selection	Explanation	Use value
PASS	Enter password	0
Add	Series address	X*
SEnSO	Select which current sensor is used	roG
Ct Prin	Nominal primary current of the current sensor	1.00k

\*The energy meters have unique serial addresses. Program and enter the selected address in the web interface under **Fuses**.

## Schneider iEM3555

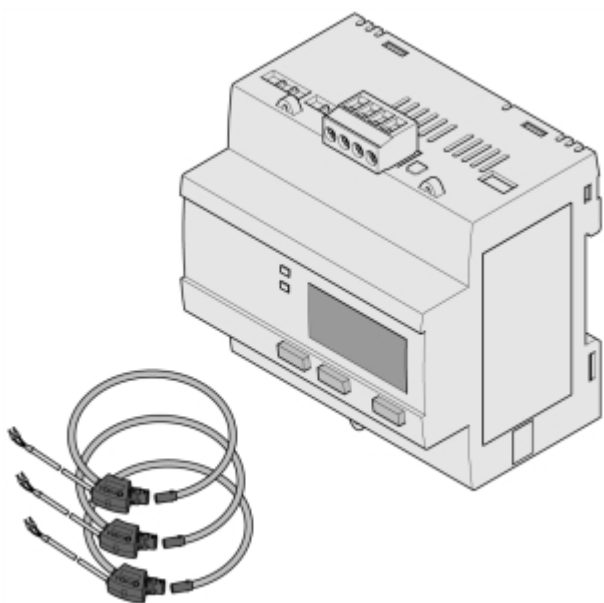

Image 85: Energy meter and current transformer for Schneider iEM3555

Product type	Model	Details
Energy meter	Schneider iEM3555	E number: 0900240
Current transformer	ROG CT 100 mV	Available in various diameters, all sizes can handle 20–4000 A



### Keep in mind!

Be sure to install the current transformers so that the current is measured in the correct direction, marked with an arrow.

## Connect the iEM3555 energy meter

- 1 The inputs (L1) S1 S2 (L2) S1 S2 (L3) S1 S2 on the energy meter are used for connecting current transformers. S1 is white and S2 is black.

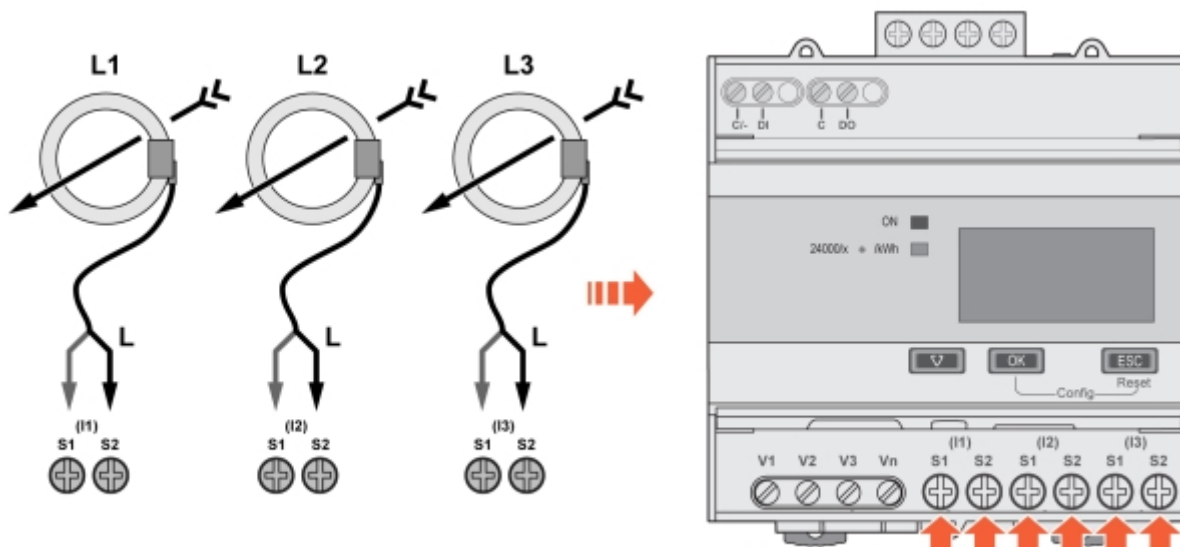

Image 86: Inputs for current transformer

- 2 The inputs V1, V2, V3, and Vn on the energy meter are used for connecting supply voltage (3-phase 230 V).

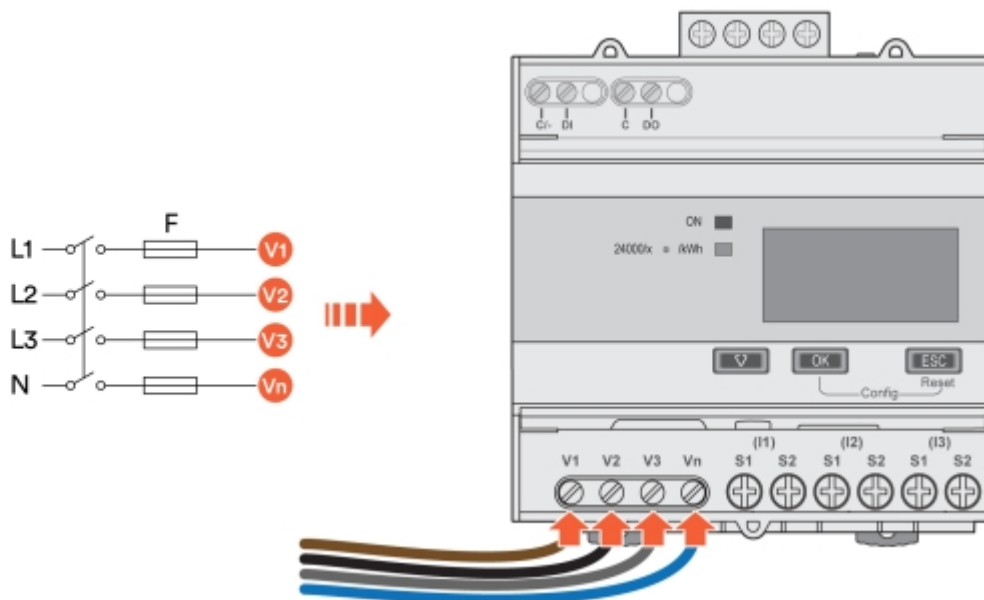

Image 87: Inputs for voltage

- 3 Input grounding, D0/- and D1/+ on the energy meter, is used for connection with RS485 (BUS).

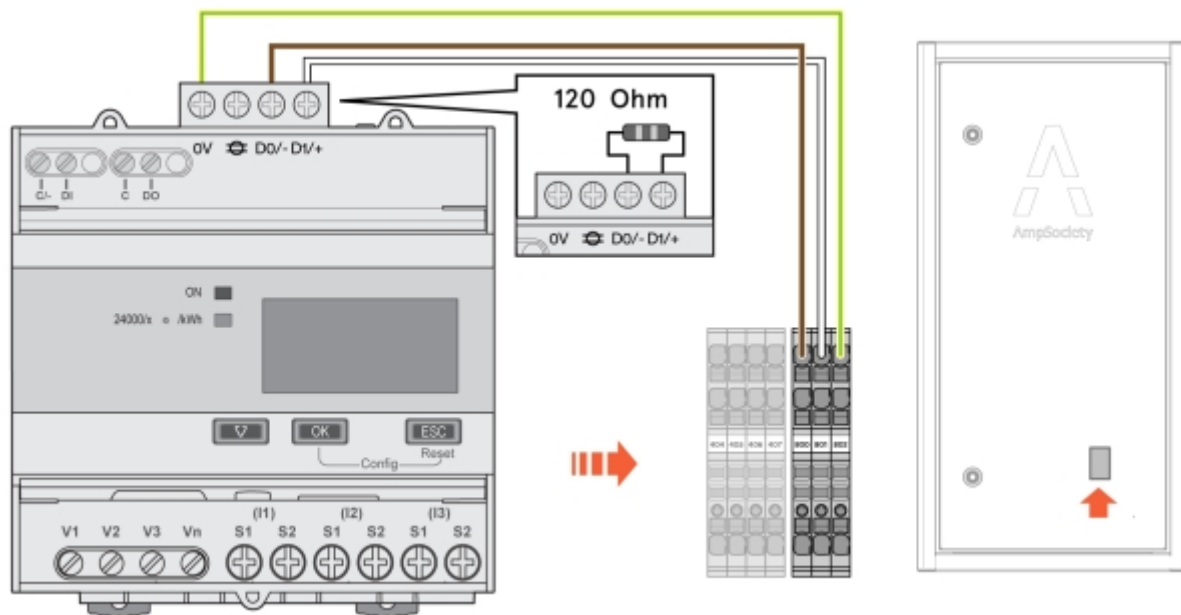

Image 88: Inputs for RS485

## Configure iEM3555 for load balancing

- 1 After completing installation, power up iEM3555.
- 2 You will be asked "Date & Time Set?". Press **ESC**. Time and date will be set later.
- 3 Press and hold **OK** and **ESC** for more than 2 seconds to start configuration.
- 4 Select Password 0010 by pressing **OK V OK OK OK**.
- 5 You will be asked "Wiring Change?". Select **OK**.
- 6 Browse through the suggestions with **V**. When it says "3PH4W," press **OK**.
- 7 For Wiring\VT, scroll between suggestions with **V**. When it says "Direct-NoVT," press **OK**.
- 8 For Wiring\CT, scroll between suggestions with **V**. When it says "3CTs on I1,I2,I3," press **OK**.
- 9 You will be asked "CT & VT Ratio Change?". Press **V** to skip.
- 10 You will be asked "Frequency Change? 50Hz". Press **V** to skip.
- 11 You will be asked "Date Change?". Select **OK**.

- 12 Set the date by changing it with **V** and confirming with **OK**.
- 13 You will be asked "Date Save Settings?". Select **OK**.
- 14 You will be asked "Time Change?". Select **OK**.
- 15 Set the time by changing it with **V** and confirming with **OK**.
- 16 You will be asked "Time Save Settings?". Select **OK**.
- 17 You will be asked "Multi Tariffs Change? Disable". Press **V** to skip.
- 18 You will be asked "Overload Alarms Change? Disable". Press **V** to skip.
- 19 You will be asked "Digital Output Change? Disable". Press **V** to skip.
- 20 You will be asked "Digital Input Change? Input Status". Press **V** to skip.
- 21 You will be asked "Demand Change?". Press **V** to skip.
- 22 You will be asked "Communication Change?". Select **OK**.
- 23 For "..\Slave Address", scroll up and select address 004 with **V**. Confirm with **OK**.
- 24 For "..\Baud Rate", scroll and select 9600 with **V**. Confirm with **OK**.
- 25 For "..\Parity", scroll and select NONE with **V**. Confirm with **OK**.
- 26 You will be asked "Communication Save Settings?". Select **OK**.
- 27 You will be asked "COM.Protection Change? Enable". Press **V** to skip.
- 28 You will be asked "Contrast Change?". Press **V** to skip.
- 29 You will be asked "Password Change?". Press **V** to skip.
- 30 You will be asked "Reset Config Reset to Default?". Press **V** to skip.
- 31 You will be asked "Exit Config Confirm?". Select **OK** to exit configuration.
- 32 To check voltage and current, press **V** until "V & I More?" appears in the display.
- 33 Select **OK**.

34 Scroll with **V** to see the different values.

## Menu options iEM3555

Below are some menu options that are relevant for the installation of dynamic load balancing with the iEM3555 energy meter.



### Keep in mind!

For complete information about the energy meter and its menu, see the product's own manual.

Menu selection	Explanation	Use value
PASS	Enter password	0010
Slave address	Series address	X*
Baud Rate	Communication speed RS485	9600
Parity	Parity bit/error detection	None

\*The energy meters have unique serial addresses. Program and enter the selected address in the web interface under **Fuses**.

## Load balancing over the internet

Amp5 supports load balancing via the internet through smart charging profiles in accordance with the Open Charge Point Protocol (OCPP) standard.

# Technical data

---

## Amp5 product specification

### Electrical specifications and charging functions

Maximum number of charging sockets	54 per SmartHub
Maximum number of simultaneous charging sessions	30 per SmartHub
Max incoming current	63 A
Max simultaneous charging power	44 kW
Maximum charging power per charging socket	22 kW (3-phase), 7.4 kW (1-phase)
Main fuse	63 A, B characteristics
Nominal insulation voltage (U <sub>i</sub> )	400 V
Nominal peak current	32 A per socket
Short-circuit capacity	0.5 kA
Rated impulse voltage (U <sub>imp</sub> )	4 kV
Reference voltage, energy meter	230 V
Min current, energy meter	250 mA
Reference current, energy meter	5 A
Max current, energy meter	32 A
Current measurement	MID certification ready in H1 2026
Charging socket	Type 2, IEC 61851
Permitted adapter	Type 2 to Schuko
Extension cable	Not permitted
Ventilated charging	Requests for ventilated charging will not be accepted
Lockable charging sockets	Yes
Charging mode	Mode 3 (IEC 61851-1)
I <sub>nc</sub> Rated current for main output circuit 63 A	0.5 kA
I <sub>ng</sub> Group's rated current for main circuit is 63 A	0.5 kA
I <sub>cw</sub> Rated short-time withstand current 63 A	0.5 kA
I <sub>cc</sub> Short-circuit current 63 A	0.5 kA
Residual Density Factor (RDF)	1
Residual Current Device (RCD)	Modular earth fault circuit breaker, type B, 30 mA, in accordance with IEC 60947-2
Main circuit breaker (MCB)	63 A, characteristic B
Rated voltage (U <sub>n</sub> )	3-phase, 400 V AC ± 10%, 50/60 Hz
<b>Safety</b>	
Residual current circuit breaker	Type B per socket (IEC 60947-2, class 1)
Grounding system	TN-C / TN-S
Measures to protect against electric shock	Class 1

Overload protection in ChargePod	1 second time delay according to IEC 60947-2, 32 A
Type of grounding	TN-C / TN-S
Mechanical strength	According to IEC 61439-7
<b>Load balancing</b>	
Static load balancing against fixed value	Yes
Dynamic load balancing	Yes, via internet or locally with Modbus TCP / RS-485
<b>Communication</b>	
Communication protocol	OCPP 1.6J / OCPP 2.0.1 / ISO15118-20 ready ISO15118-2:MAC identification
Network connection (option)	Teltonika RUT 901 with 4G SIM card and LAN. Wi-Fi hotspot (for configuration only)
RF technology	GSM, GPRS, EDGE, UMTS/HSPA+, LTE
RFID type	ISO/IEC 14443 Type A, 13.56 MHz Mifare
Data and network interfaces	USB-C, 2xLAN, Bluetooth, Service Wi-Fi, and RFID in accordance with EN 18031
Potential-free emergency stop input	Yes
<b>Certification</b>	
EMC classification	Environment B
Degree of contamination	3
IP rating	IP54
IK rating	IK10
<b>Environment</b>	
Operating temperature	-30°C to +45°C, air temperature
Temperature range, not in operation	-30°C to +65°C, condensation free
Suitable installation environment	B, indoors and outdoors
Installation	Stationary installation on wall or ground
Use and access	Available to all users without restrictions
<b>Materials and mechanics</b>	
Material	Aluminium, at least 75% recycled aluminium (post-consumer scrap)
Colour	Black (RAL 9011), powder coated
<b>Weight</b>	
SmartHub L/R ConnectBar (with cables and power bar)	22 kg
SmartHub standalone (with cables and power bar)	21 kg
GroundBase for SmartHub	4.5–5 kg
Pole bracket set	3.35 kg
Wall bracket set	2 kg
ConnectBar EndModule	1.3 kg
ConnectBar WallConnection (without JunctionBox)	1.7 kg
ConnectBar GroundConnection	1.7 kg (upper section) 3.4 kg/m (lower section)
Pole bracket short set	2 kg

Wall bracket short set	0.24 kg
ConnectBar Wall Start module	1.7 kg
ConnectCover	2.2 kg
ChargePod 1 (all variants)	5 kg
ChargeHook	0.345 kg
ConnectCable 6 m	7.6 kg
ConnectCable 3 m	4.2 kg
Ground pipe adapter	0.264 kg
SmartHub base 15 cm	1.1 kg
JunctionBox v2	0.385 kg
<b>Dimensions (H × D × W mm)</b>	
SmartHub L/R ConnectBar (with cables and power bar)	1140 × 130 × 760
SmartHub standalone (with cables and power bar)	800 × 130 × 410
GroundBase for SmartHub	1200 × 130 × 405
Pole bracket set	1500 × 115 × 880
Wall bracket set	125 × 155 × 880
ConnectBar EndModule	200 × 130 × 225
ConnectBar WallConnection (without JunctionBox)	200 × 130 × 460
ConnectBar GroundConnection	530 × 130 × 460
Pole bracket short set	1490 × 115 × 110
Wall bracket short set	125 × 170 × 110
ConnectBar Wall Start module	200 × 130 × 465
ConnectCover	170 × 130 × 710
ChargePod 1 (all variants)	170 × 130 × 710
ChargeHook	155 × 80 × 100
ConnectCable 6 m	85 × 95 × 6000
ConnectCable 3 m	85 × 95 × 3000
Ground pipe adapter	45 × 135 × 200
SmartHub base 15 cm	150 × 130 × 410
JunctionBox v2	85 × 110 × 200
<b>Features</b>	
Display	TFT 480 × 272 px, 160 × 131.71 mm (H × D × W)
Customisable display content	Logo, QR code, prices, etc.
Test button for residual current circuit breaker	Yes
Lock	Stockholm lock, lock bolt with key
User interaction	Via QR code and RFID
<b>Battery</b>	
Battery backup (UPS)	Capacitor

## Ground anchorage

Make	Stabil Entreprenad
Type	SGN pipe screw
Supplier part number	3002
Surface treatment	Galvanised
Length	865 mm
Outer diameter	67 mm
Inner diameter	64 mm
Warranty	25 years from supplier
Standards	Material ISO 630 FE 360A
	Product EN 1090
	Galvanisation EN 1461
	Manufacturing process ISO 9001:2015
	Installation process ISO 9001:2015

Alternative ground screws, ground spikes and ground foundations can be used where the substrate requires such. See the following examples.

Make	Fiedler System AB
Type	Ground spike
Supplier part number	40100
Surface treatment	Galvanised sheet C3/C5
Length	720 mm
Outer diameter	95 mm
Inner diameter	66–76 mm
Warranty	Normal life expectancy 95 years

Make	AmpSociety International AB
Type	PoleBase
Supplier part number	5000262
Surface treatment	Electro galvanization, powder coating
Length	171 mm
Inner diameter of pipes	60 mm
Warranty	5 years



# AmpSociety

**Charging without compromise**

## Contact

AmpSociety International AB | Neongatan 4B | 431 53 | Mölndal  
+46 101 499 500  
[info@ampsociety.com](mailto:info@ampsociety.com)  
[www.ampsociety.com](http://www.ampsociety.com)



5000268